

BRIDGE PIER, BRIDGE ABUTMENT,
HANDRAIL, UTILITY POLE, CULVERT
HEADWALL, ETC, WHEN LESS THAN
8' FROM THE PAVED SURFACE.

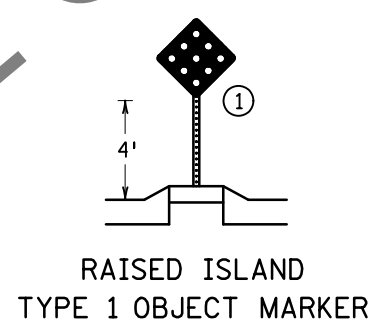

MARKER TYPICAL PLACEMENT

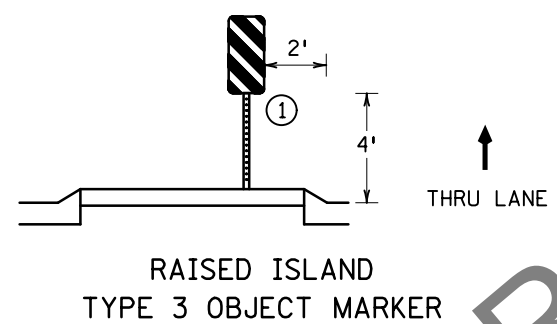
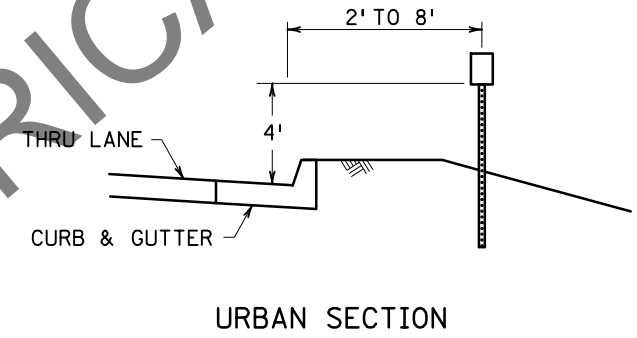
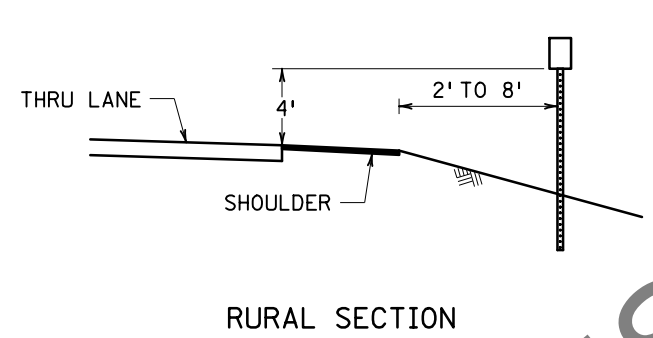

DELINEATOR TYPICAL PLACEMENT

NOTES:

- ① MARKER SHOULD BE PLACED AS CLOSE TO THE BEGINNING OF MEDIAN AS POSSIBLE.
- ② THE EDGE OF THE OBJECT MARKER THAT IS CLOSEST TO THE ROAD USER SHALL BE PLACED IN LINE WITH THE CLOSEST EDGE OF THE OBSTRUCTION. STRIPES SHALL BE ANGLED DOWNWARD TOWARDS THE SIDE TRAFFIC IS TO PASS THE OBSTRUCTION.

REVISION:
APPROVED: OCTOBER 16, 2019
Brian Subenson
BRIAN SUBENSON
STATE TRAFFIC ENGINEER

m MINNESOTA
DEPARTMENT OF TRANSPORTATION
STANDARD PLAN 5-297.702 1 OF 1
Peter A Harff APPROVED: 10-16-2019
PETER A. HARFF
STATE DESIGN ENGINEER
REVISI

DELINEATOR AND MARKER PLACEMENT

STATE PROJ. NO. (T.H.) SHEET NO. OF SHEETS