

NOTES:

SEE INTERSECTION LAYOUT FOR CABLE INFORMATION.

FOR THE EQUIPMENT PAD, USE CONCRETE MIX 3G52 WITH APPROVED MACRO NON-METALLIC FIBERS FOR REINFORCEMENT. THESE ARE LISTED ON MnDOT'S APL UNDER CONCRETE "NONMETALLIC FIBERS (BRIDGE APPLICATIONS)." ADD FIBERS TO THE CONCRETE MIX IN ACCORDANCE WITH THE NON-METALLIC FIBERS MANUFACTURER'S INSTRUCTIONS AND CONTRACT DOCUMENTS.

FOR CONCRETE WALK, USE CONCRETE MIX 3G52. 3G52 CONCRETE MIX WITH NON-METALLIC FIBERS MAY BE USED FOR THE CONCRETE WALK AND POLE FOUNDATIONS. DO NOT USE NON-METALLIC FIBERS AS A SUBSTITUTE FOR THE REQUIRED REINFORCEMENT IN ACCORDANCE WITH THE POLE FOUNDATION STANDARD PLATES.

IF THE SITE CONDITIONS REQUIRE THE PAD TO BE PLACED ON A SLOPE, INCREASE THE THICKNESS OF THE PAD BY 6". SHAPE THE TERRAIN AROUND THE PAD FOR PROPER DRAINAGE.

3" MINIMUM CLEAR REQUIRED BETWEEN THE TOP AND BOTTOM SURFACES OF THE PAD AND THE OUTSIDE OF THE CONDUIT.

ENSURE THE CONDUITS FULLY ENCASED IN CONCRETE FROM ONE CABINET TO THE OTHER ARE PLACED AT THE CORRECT DEPTH AND LOCATION TO AVOID INTERFERENCE WITH THE INSTALLATION OF THE ANCHOR RODS.

① PLACE A GROUNDING ELECTRODE SYSTEM IN ACCORDANCE WITH THE GROUNDING ELECTRODE SYSTEM DETAIL ON STANDARD PLATE 8106 SHEET 3 EXCEPT FURNISH AND INSTALL 10' GROUND ROD ELECTRODES, 6 AWG GREEN INSULATED COPPER CONDUCTOR, AND EXOTHERMIC WELDED CONNECTIONS. IF A MnDOT TRAFFIC SIGNAL SYSTEM HAND HOLE IS LOCATED AT LEAST 6' APART AND NO MORE THAN 10' APART FROM THE GROUND ROD LOCATED IN THE EQUIPMENT PAD, THE SUPPLEMENTAL GROUND ROD MAY BE PLACED IN THAT HANDHOLE. USE A 12' GROUND ROD IN THE HAND HOLE INSTEAD OF A 10' GROUND ROD AND PULL A GREEN INSULATED 6 AWG CONDUCTOR IN THE CONDUIT GOING TO THAT HAND HOLE. IF THE REQUIRED TRAFFIC SIGNAL POLE HANDHOLE GROUND ROD IS LOCATED WITHIN THE SPECIFIED DISTANCE MENTIONED, BOND THE GREEN INSULATED 6 AWG CONDUCTOR TO THAT GROUND ROD.

② CONDUIT SIZE, QUANTITY, AND DIRECTION MAY VARY. FURNISH AND INSTALL CONDUITS AS SPECIFIED ON THE INTERSECTION LAYOUT PLAN SHEET. ENSURE CONDUITS ARE NOT PLACED DIRECTLY UNDER ANCHOR ROD LOCATIONS.

③ USE TEMPLATES WITH THE DIMENSIONS SHOWN INCLUDING OPENINGS, DIVIDERS, AND ANCHOR ROD HOLES AS A GUIDE TO ENSURE PROPER PLACEMENT OF THE CABINETS, CONDUITS, AND ANCHOR RODS. 350 BASE OPENINGS FOR TEMPLATE ARE SMALLER THAN THE ACTUAL BASE OPENINGS.

④ SET ANCHOR RODS IN THE CONCRETE PAD WITH A 2" TO 2 1/4" PROJECTION ABOVE THE PAD. FURNISH AND INSTALL ANCHOR RODS SHOWN ON THE ANCHOR ROD DETAIL IF WET-CASTING ANCHORS IN CONCRETE. FURNISH AND INSTALL ANCHOR RODS SHOWN ON THE ANCHOR ROD DETAIL IF USING AN ADHESIVE ANCHORING SYSTEM. WHEN USING THE ADHESIVE, FULLY INSERT THE 3/4" Ø X 8" LONG ANCHOR RODS INTO 6" DEEP DRILLED HOLES IN THE PAD AT THE LOCATIONS SHOWN ON THE ANCHOR ROD LOCATION DETAIL. DRILL THE HOLES TO THE DIAMETER SIZE SHOWN IN THE ADHESIVE MANUFACTURER'S PRINTED INSTALLATION INSTRUCTIONS FOR 3/4" Ø RODS. FOLLOW THE ADHESIVE MANUFACTURER'S PRINTED INSTALLATION INSTRUCTIONS INCLUDING CURE TIME AND GEL TIME BASED ON CONCRETE TEMPERATURE. USE AN APPROVED ADHESIVE ANCHORING SYSTEM LISTED ON MnDOT'S APL UNDER SIGNALS/PEDESTRIAN PUSHBUTTONS AND MOUNTING HARDWARE.

⑤ FURNISH AND INSTALL A DRAIN IN THE PAD USING 1" SCHEDULE 40 PVC PIPE. PLACE PVC TERMINATION VENT SCREEN DESIGNED FOR PVC PIPE AT EACH END OF THE PIPE. PROVIDE PVC TERMINATION VENTS WITH A STAINLESS STEEL SCREEN. ENSURE THE TERMINATION VENT SCREEN AND PIPE ARE FLUSH WITH THE TOP AND SIDE OF THE PAD AND PROTECT FROM CONCRETE INTRUSION BEFORE CONCRETE PLACEMENT OPERATIONS.

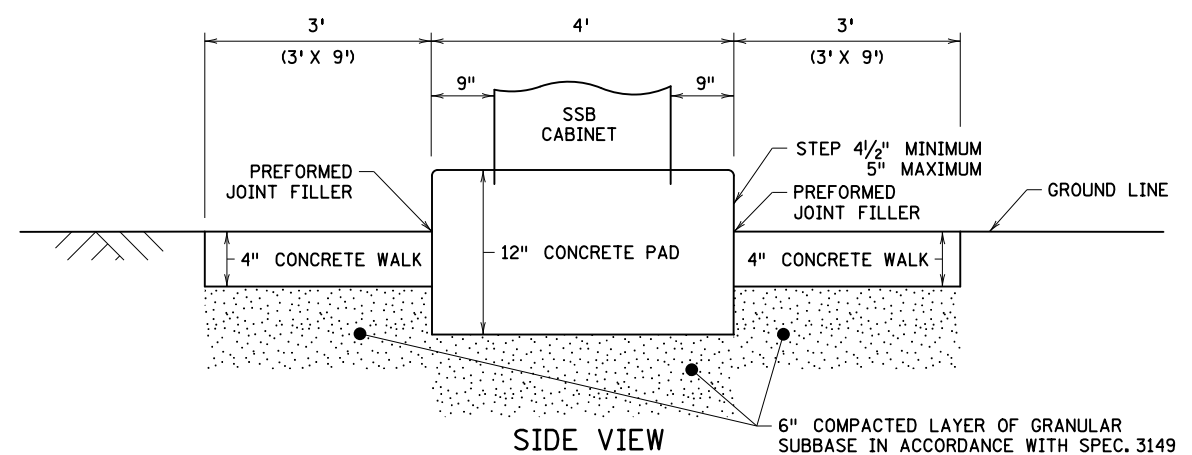
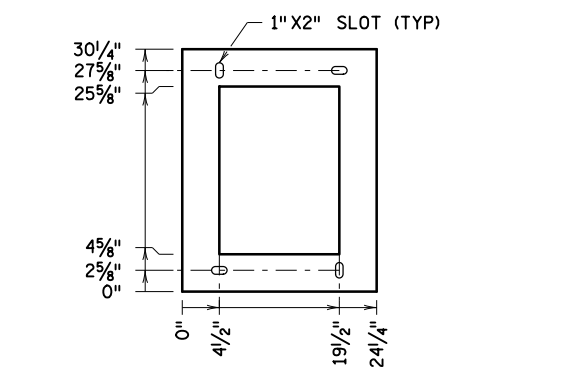
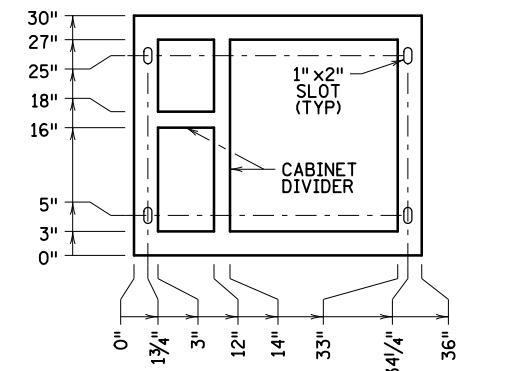
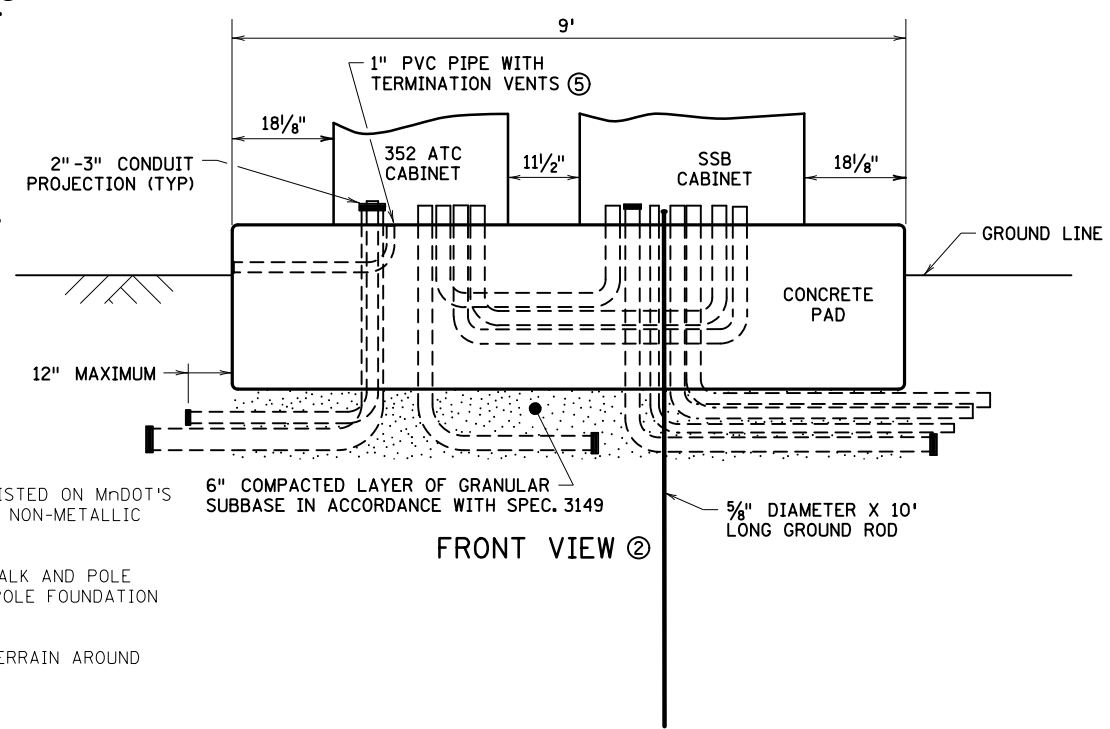

LEAD EXPERT OFFICE BRIAN SORENSON STATE TRAFFIC ENGINEER OFFICE OF TRAFFIC ENGINEERING	352 ATCC AND SSB CABINET EQUIPMENT PAD CAST IN PLACE	APPROVED: 02-22-2022 REVISED:	 THOMAS STYRBICKI STATE DESIGN ENGINEER	STANDARD PLAN 5-297.870	1 OF 1
				STANDARD PLAN	STATE PROJ. NO. TRUNK HWY.



STANDARD PLAN