



Design Scene Part 2 – Plan Conventions

Chapter 11 Walls

9/23/2022

Contents

Design Scene Part 2 – Plan Conventions	1
Chapter 11 Walls	3
Modular Block Wall (Dry Cast).....	3
Prefabricated Modular Block Wall (Wet Cast).....	3
PMBW Guidelines for Roadway Designers	5
Retaining Walls	10

Chapter 11 Walls

Modular Block Wall (Dry Cast)

The Approved/Qualified Modular Block Walls (MBW) (Dry Cast) components and systems are located:

[Dry Cast Walls - Approved/Qualified Products](#)

[Dry Cast Wall Systems - Approved/Qualified Products](#)

[Segmental Masonry Wall Sealants - Approved/Qualified Products](#)

The engineering design of MBW's is standardized and the standards are located at:

[MnDOT Standard Plans](#)

There are several restrictions to MBWs located in the expired MnDOT Tech Memo No. [14-03-MAT-01](#) "Use of Dry-Cast Segmental Masonry Retaining Wall Units". Some of these restrictions are summarized below:

No MBWs are allowed in locations where they will be directly supporting roadways or bridge abutments as defined by a 0.5 H:1.0 V line extending up from the bottom back of the reinforcement zone.

There will be no restrictions (beyond those listed above) for the location of walls less than or equal to 4 ft in height (nominal height including terraces).

For MBWs only, the allowable placement locations for walls greater than 4 ft in height (nominal dimension) are as follows:

Roadways with traffic volumes less than or equal to 5000 AADT - No restriction in location.

Roadways with traffic volumes between 5000 and 20000 AADT - The face of block of the walls must be located more than 20 ft beyond the outside shoulder edge or gutter line.

Roadways with traffic volumes greater than or equal to 20000 AADT - The face of block of the walls must be located greater than 30 ft beyond the outside shoulder edge or gutter line.

For MBWs only, the maximum allowable nominal exposed wall height, including terraces, will be 10 ft.

For MBWs only, all placement restrictions are measured from the front face of block.

The pay item for MBW's is 2411.618 MODULAR BLOCK RETAINING WALL by SQ FT.

Prefabricated Modular Block Wall (Wet Cast)

Prefabricated modular block walls (PMBWs) are systems which contain wet cast precast concrete units, interlocking soil-filled reinforced concrete modules or bins or rock filled gabion baskets. Modular block walls (MBWs) are systems which contain dry cast precast concrete units. Both wet cast PMBWs and dry cast MBWs resist horizontal earth pressure by acting as gravity retaining walls. Soil reinforcement can be added to wet cast PMBWs and dry cast MBWs to cause them to act as hybrid systems. In these systems the reinforced soil mass and weight of the units are used to resist the external horizontal earth pressure and other loads.

Dry cast MBWs have standards and technical memoranda that cover their design, while PMBW are complete prequalified engineered systems which consist of components such as block units, soil reinforcement, connections, and geotextiles. A multidisciplinary team of MnDOT engineers reviews each system before it is prequalified to bid on MnDOT projects. For PMBW, MnDOT divides the prequalification requirements into three phases:

Prefabricated Modular Block Wall (Wet Cast)

1. Phase I: Gravity PMBW (No soil reinforcement). The maximum exposed height of these systems is 8 ft, where *exposed height* is defined as the distance from the finished ground line at the top of the wall to the finished ground line at the base of the wall. Since this is a gravity system with no redundancy, this wall type is not allowed to support a roadway. (See Definition of Supporting Traffic: Gravity PMBW below for the definition of supporting a roadway)
2. Phase II: PMBW with soil reinforcement. The maximum exposed height of these systems is 10 ft. These are hybrid systems in which the reinforced soil mass and weight of the units are used to resist the external horizontal earth pressure and other loads. Since soil reinforcement is used, the units are typically shallower than in a gravity PMBW system. Properly designed, these wall systems can be used to support an adjacent roadway.
3. Phase III: PMBW with soil reinforcement. The maximum exposed height of these systems is 18 ft. Like Phase II systems, these are hybrid systems in which the reinforced soil mass and weight of the units are used to resist the external horizontal earth pressure and other loads. Since soil reinforcement is used, this type of unit is typically shallower than in a gravity PMBW system. The difference between Phase II and Phase III systems is that Phase III systems require more scrutiny during the prequalification process. The application for prequalification in a Phase III system requires a completed technical evaluation report from the Highway Innovative Technology Evaluation Center (HITEC) or an independent review by an equivalent MnDOT approved MSE wall system expert for compliance with AASHTO requirements and a review by a multidisciplinary team of MnDOT engineers. Properly designed, these wall systems can be used to support an adjacent roadway.

The MnDOT prequalified suppliers list for Phase I is located:

[Prefabricated Modular Gravity Block Walls - Approved/Qualified Products](#)

The MnDOT prequalified suppliers list for Phase II and Phase III is located:

[Prefabricated Modular Block Walls - Approved/Qualified Products](#)

Definition of Supporting Traffic: Gravity PMBW

Gravity PMBW are not allowed to support traffic. A vehicular roadway or parking lot shall not be situated within a 1V:1H horizontal distance measured from the front face bottom corner of the bottom block (see Figure 1). The horizontal distance shall be determined for each wall measured at the highest portion of the wall. Since no vehicular live load is applied, a surcharge must be applied to account for snow loads, future maintenance operations, or future regrading.

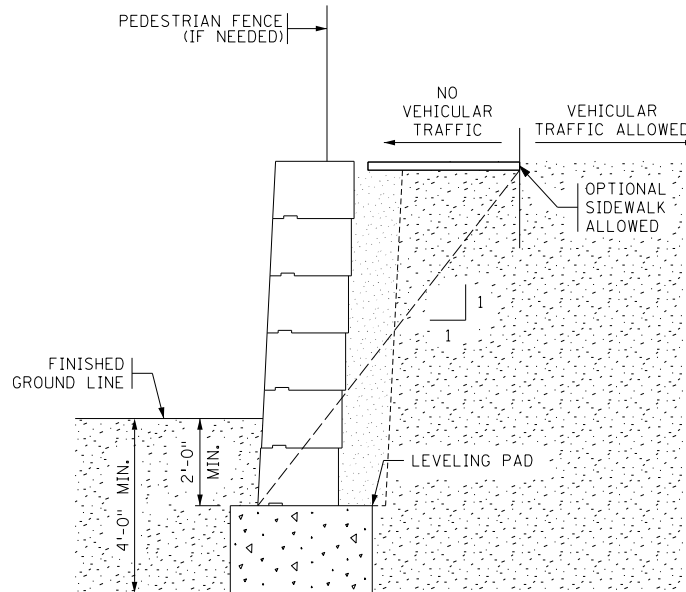

Figure 1 Definition of Supporting Traffic for a Gravity PMBW

Definition of Supporting Traffic: PMBWs with Soil Reinforcement

PMBWs with soil reinforcement are considered to support traffic if a vehicular roadway or parking lot is located within a horizontal distance measured from the front face of the bottom block equal to $(D_u + L + 0.5 RH)$, where:

D_u = Depth of the Unit (assume 3')

L = Length of Reinforcement (Minimum of $0.7 \times RH$ or 8')

RH = Design Height of PMBW with Soil Reinforcement

The horizontal distance shall be determined for each wall measured at the highest portion of the wall. Due to grading, design, and visual quality issues between the edge of pavement or roadway and the back of a wall, traffic may not be placed within a horizontal distance of 11' (assumes 3' block depth + 8' behind back of wall) from the front face of the wall, regardless of height (See Figure 2).

PMBW Guidelines for Roadway Designers

The following are some of the key guidelines for roadway designers when using PMBWs.

Work with the geotechnical engineer to obtain a Foundation and Analysis Design Recommendation (FADR) before the wall selection process. At a minimum the FADR should consider the following:

Global stability should be addressed in the report.

Strength parameters, including the friction angles and cohesion (if applicable) of the in-situ soils, should be listed.

Static and high groundwater levels should be listed.

Predicted total and differential settlement should be listed. Differential settlement shall be less than 1/200 along the length of the wall and normal to the wall alignment.

PMBW's (gravity or reinforced) should only be used on projects where the roadway designer has verified that the ground water table is below the elevation of the proposed leveling pad AND all drainage systems installed behind the wall can be day-lighted to a ditch or subsurface drainage system. If these conditions cannot be met or verified by the roadway designer, this type of wall system should not be specified. Design or installation of prefabricated modular block walls in "bath tub" conditions or in un-drained soils is prohibited.

No drainage systems other than what is required for the wall and highway drainage shall be placed within the reinforced soil zone. The wall design shall include the necessary details or design modifications to accommodate the drainage system. The placement of the drainage system shall occur only during construction backfilling of the wall.

PMBWs with soil reinforcement shall include a drainage system on top of the concrete leveling pad at the interface of the reinforced and the retained soil (see Figure 3).

Only PMBW systems listed on the MnDOT prequalified supplier list at the letting date will be allowed.

Check with the Bridge Office if there are structures or large signs supported by the wall.

State the prequalification phase(s) (I,II or III) required for the project.

Corners are limited to 90 degrees inside and outside corners. Minimum radius for PMBW is 15'.

No drilling or driving of posts (sign, guardrail, etc.) or other roadside hardware in the reinforced zone shall occur after placement of the reinforced soil. If such roadside hardware is required, the design and plans shall include details such as sleeves to accommodate it. If a railing or fence post is placed on the top of the blocks, the designer needs to have a note on the plan requiring the wall supplier to be prequalified for the railing placement.

Depending on PMBW wall height variations, sometimes it may be desirable to use both gravity and reinforced wall types on the same wall. In these situations, gravity walls shall be used to a maximum wall height of 8' exposed and reinforced walls used to a maximum height of 18' exposed.

The same pay item, 2411.618 PREFABRICATED MODULAR BLOCK WALL, by SQ FT. shall be used for both gravity and reinforced PMBWs.

Decide on architectural details, including surface pattern and texture, joint layout and details, and surface finish and color.

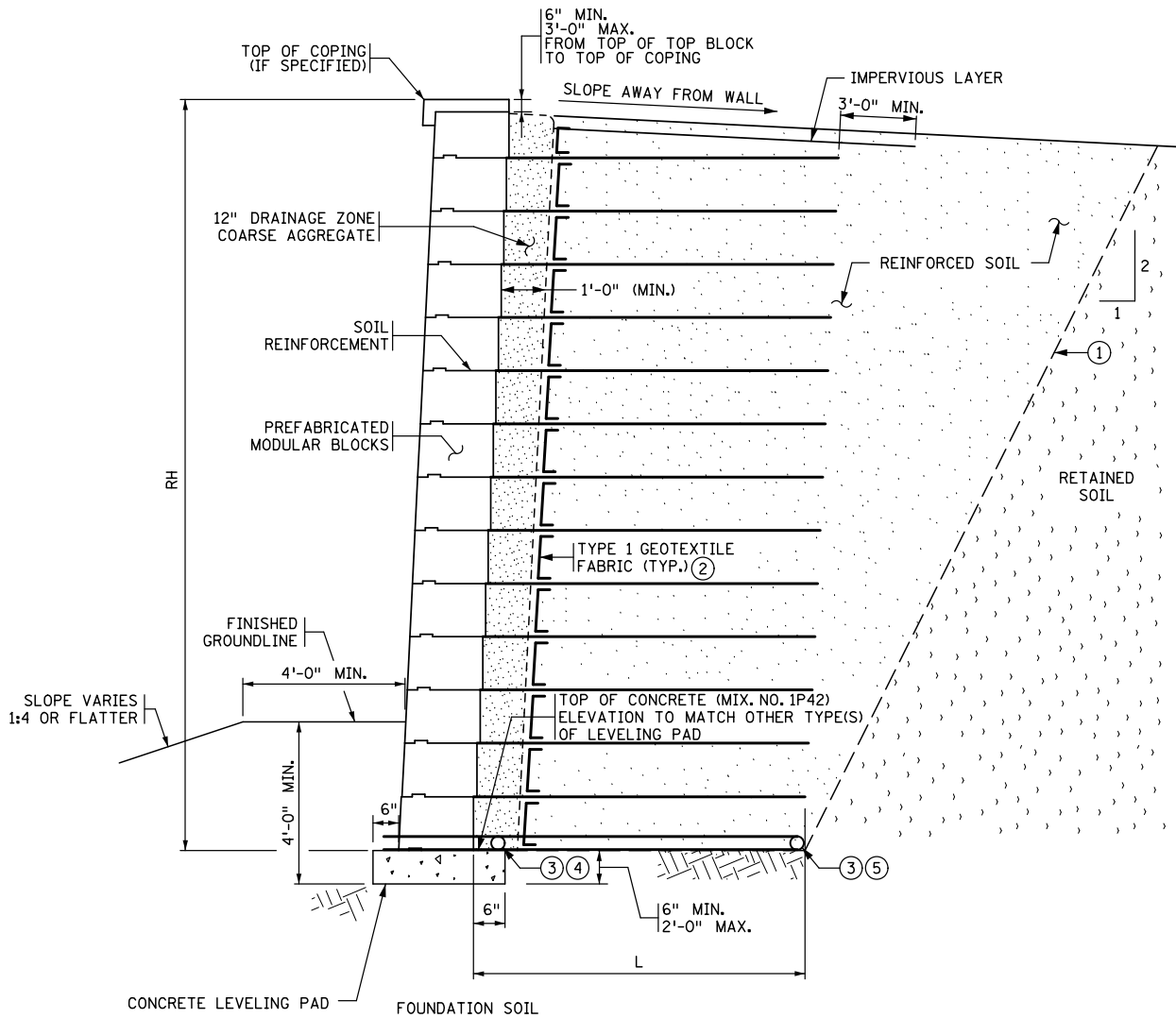

TYPICAL SECTION OF PMBW WITH SOIL REINFORCEMENT

NOT TO SCALE
LEVEL FILL

- ① PAY LIMITS (2V:1H). ACTUAL EXCAVATION SLOPE IS DETERMINED BY OSHA REGULATIONS AND IN-SITU SOILS; EXCAVATION BEYOND THESE LIMITS AT CONTRACTORS EXPENSE.
- ② THE WRAP LENGTH FOR GEOTEXTILE FABRIC SHALL NOT BE MORE THAN 6".
- ③ 4" THERMOPLASTIC PERFORATED PIPE, SPEC. 3245. WRAP WITH TYPE 1 GEOTEXTILE, SPEC. 3733, INSTALLATION AS PER SPEC. 2502. CONNECT TO DRAINAGE SYSTEM OR OUTLET THROUGH WALL USING 6" T.P. NON-PERFORATED PIPE WITH RODENT SCREEN. ALL WORK INCIDENTAL
- ④ FRONT DRAINTILE.
- ⑤ BACK DRAINTILE.

Figure 3: PMBW with Soil Reinforcement Material Definitions/ Typical Cross Section

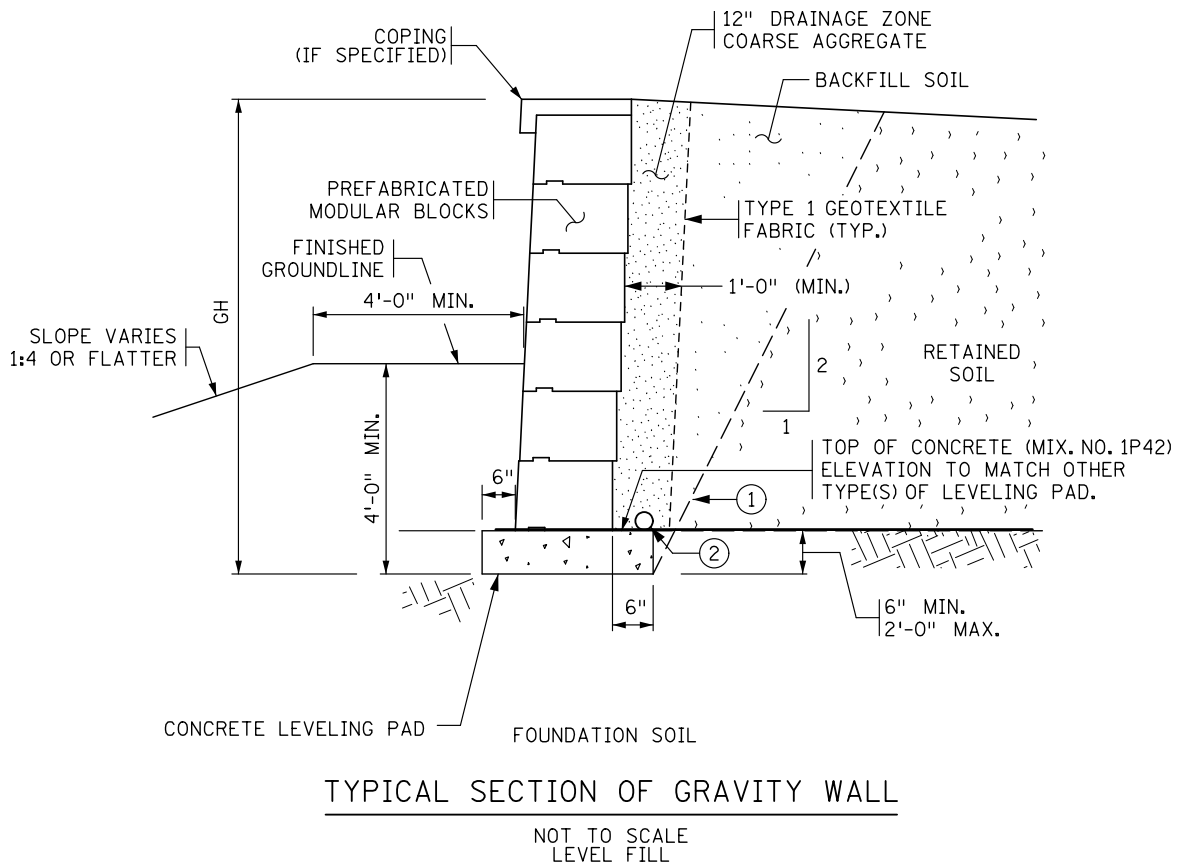

- ① PAY LIMIT (2:V TO 1:H) ACTUAL EXCAVATION SLOPE IS DETERMINED BY DESIGNER PREFERENCE OR OSHA REGULATIONS OF IN-SITU SOILS; EXCAVATION BEYOND THESE LIMITS AT CONTRACTORS EXPENSE.
- ② 4" THERMOPLASTIC PERFORATED PIPE, SPEC. 3245. WRAP WITH TYPE 1 GEOTEXTILE, SPEC. 3733, INSTALLATION AS PER SPEC. 2502. CONNECT TO DRAINAGE SYSTEM OR OUTLET THROUGH WALL USING 6" T.P. NON-PERFORATED PIPE WITH RODENT SCREEN. ALL WORK INCIDENTAL.

Figure 4: Gravity PMBW Material Definitions/ Typical Cross Sections

Gravity PMBWs can have either a 2' concrete leveling pad or a composite leveling pad consisting of 6" min. of concrete and coarse filter aggregate. In either case, the bottom of the leveling pad must be at least 4' below the finished ground line at the bottom of the wall.

Gravity PMBWs with a concrete-only leveling pad shall include a drainage system on top of the concrete leveling pad (see Figure 5). The drainage system shall consist of perforated pipe per MnDOT 3245 wrapped with a type 1 geotextile per MnDOT 3733. The pipe shall be placed such that water drains freely from the pipe, typically at a 1% grade with 3 foot minimum radius bends. Provide outlets as required due to expected flow rate with a maximum spacing of 150 feet. Outlet the drainage system through the slope in front of the wall with a concrete headwall per MnDOT Standard Plate 3131 or into a drainage structure (see Figure 3). The designer shall take into account the location of wall drainage systems in the layout and step locations of wall leveling pads and ensure the wall drainage system is compatible with the leveling pad step locations. The shop drawings for each wall shall denote the location of the drainage system components, including the station of each outlet penetration

through the wall and whether the flow is outletted through the slope in front of the wall or into a drainage structure.

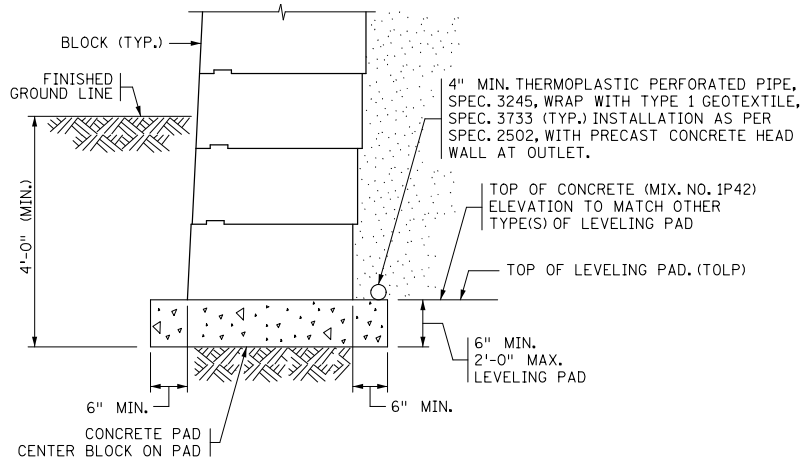

Figure 5 – Full depth concrete leveling pad detail

The composite leveling pad shall consist of a 6" min. thickness concrete slab over a 6" min. thickness of compacted drainable coarse filter aggregate per MnDOT Spec 3149.2H. The coarse filter aggregate shall be completely wrapped with a Type 1 geotextile fabric per MnDOT Spec 3733 (see Figure 6). The bottom of the leveling pad must extend at least 4' below grade. Drains shall be required at the bottom of the coarse filter aggregate and directly above the concrete.

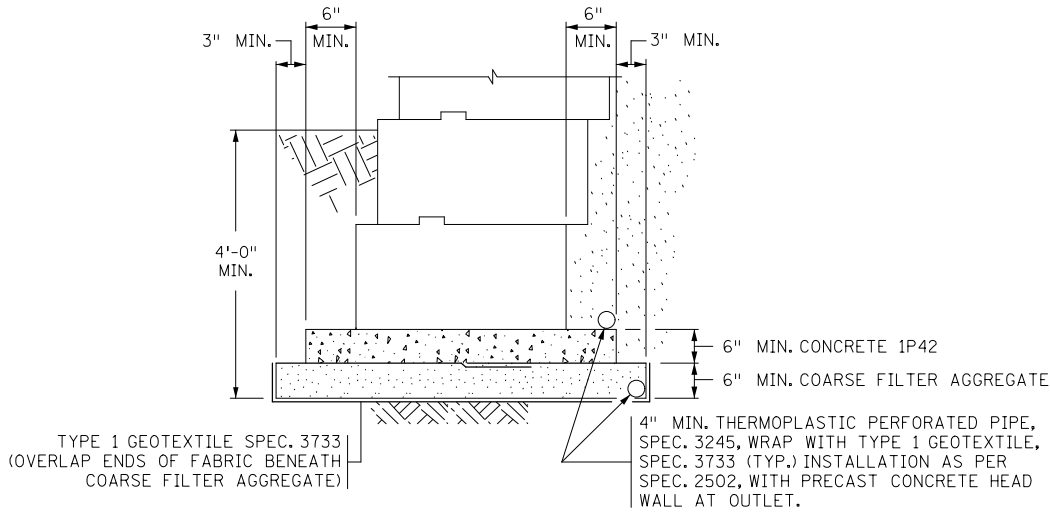

Figure 6 - Composite leveling pad detail (gravity walls only)

The pay item for PMBW's is 2411.618 PREFABRICATED MODULAR BLOCK WALL by SQ FT.

Retaining Walls

The following is in the process of being prepared for possible inclusion into the RDM. The information was deemed important so that it is incorporated in the Design Scene for designer's information.

Standard plans for cast-in-place retaining walls are included in the Standards Plans Manual or at the following website... MnDOT Standard Plans

on sheets 5-297.620 through 5-297.639. The plans include standard designs for wall heights up to 30 feet with three loading conditions and two types of foundations: spread or pile. The loading conditions are:

1. Level Backfill
2. Level backfill with 2 ft. live load surcharge (roadway adjacent to top of wall)
3. 1:2 sloped backfill

These standard designs are in accordance with AASHTO LRFD Specifications using the design parameters shown on Standard Plan sheet 5-297.639. A Foundations Report is prepared for each specified wall project and contains a footing recommendation.

Alternate wall designs are non-standard designs consisting of either proprietary or special wall designs.

Proprietary designed walls are provided by vendors from pre-qualified product lists that meet project specifications. All mechanically stabilized earth (MSE) walls fall into this category including prefabricated large wet-cast concrete modular block walls.

Mechanically stabilized earthen panel walls and prefabricated large wet-cast concrete modular block should only be used on projects where the roadway designer has verified that the ground water table is below the elevation of the proposed leveling pad AND that all drainage systems installed behind the wall can be day lighted to a ditch or subsurface drainage system. If these conditions cannot be met or verified by the roadway designer this type of wall system should not be specified (An exception to this requirement may be granted for gabion basket walls by the Foundations Unit). Design or installation of mechanically stabilized earth walls in "bath tub" conditions or in undrained soils is prohibited.

Specially designed walls do not fall into the standard or proprietary wall categories. These include cast-in-place cantilever walls taller than those shown on the standard plan sheets, steel sheet pile, soil nail, soldier pile and anchored walls.

Design Responsibility

The roadway designer has the responsibility to lead the plan development effort by coordinating the wall type selection process. The designer shall collect from the offices listed below the aesthetic requirements and the technical recommendations regarding the structural and foundation aspects of the wall. All various wall types described later in this section should be considered in the selection process so that the most cost-effective and appropriate wall is constructed.

The road designer also has the responsibility to develop the plan, profile, cross sections and staging of the retaining wall and to prepare the construction plans.

The Structural Wall Committee (SWC) is responsible for establishing guidelines for submittals and for submittal review of new wall types used in MnDOT projects. The approved wall systems are listed on MnDOT Approved Products website.

Standard cast-in-place wall designs which cover a wide range of situations are available in the the Standard Plans Manual. These standard designs were developed by the Bridge Office and may be used without a structural review. Alternate and non-standard designs, which include proprietary walls and walls not covered by available standards, require a special design by the Bridge Office or a consultant. It is the responsibility of the road designer to contact the Bridge Office to determine whether the non-standard wall design is completed by the Bridge Office or by others and to determine the timing and work effort involved.

The Foundations Unit is responsible for all geotechnical aspects of retaining walls and for preparing a foundation report for all wall types suggested by the road designer. The Foundations Unit should coordinate the subsurface investigation, perform laboratory analysis/testing, conduct a global and compound stability analysis (if required) and provide recommendations for the in-situ soil design parameters and foundation type. This responsibility is deferred to the District Soils Engineer for walls less than 5 feet high.

The Office of Environmental Stewardship, Environmental Planning and Design Unit and the Bridge Office Architecture Specialist, should be contacted regarding aesthetic and/or rustication treatments for retaining walls.

Preparation of Bid Documents and Plans

Wall plans fall into three categories; standard design, special design, and proprietary design. Currently, cast-in-place cantilever walls and dry cast concrete modular block walls have standard plan sheets. Preparation of plans and bid documents for all walls excluding proprietary walls should include complete details necessary for the construction of the walls using the standard plan sheets and specifications in combination with project specific information shown on additional sheets.

Special design walls include cast-in-place cantilever walls taller than those shown on the standard sheets, steel sheet pile, soil nail, soldier pile and anchored walls. Preparation of plans for these walls should include complete details necessary for the construction of the wall using project specific details and any standards or special requirements that may apply.

Plans for proprietary design walls should include pertinent information necessary for location and alignment including cross sections, plans, and profiles. Locations of drainage systems, utilities or other features impacting the design or construction should also be shown. The balance of the details necessary for construction shall be provided by the wall vendor via the contractor as described in the Special Provisions.

Proprietary Designed walls

Per MnDOT specifications, all proprietary designed walls will be selected from the MnDOT Pre-qualified supplier lists, so it is not necessary to get a public interest finding for walls meeting the specifications.

All proprietary wall designs shall contain the following geometric and project specific information:

1. List of acceptable wall types and/or systems for each wall on the project.
2. Drainage - Proprietary designed walls shall include a drainage system consisting of perforated pipe per MnDOT 3245 wrapped with a type 1 geotextile per MnDOT 3733. The pipe shall be placed such that water

drains freely from the pipe, typically a 1% grade and 3 foot minimum radius bends. Provide outlets as required due to expected flow rate with a maximum spacing of 150 feet. Outlet the drainage system through the slope in front of the wall with a concrete headwall per MnDOT Standard Plate 3131 or into a drainage structure. The designer shall take into account the location of wall drainage systems in the layout and step locations of wall leveling pads and to ensure the wall drainage system is compatible with the leveling pad step locations. The designer shall denote the location of the drainage system components, including the station of each outlet penetration through the wall and whether the flow is outletted through the slope in front of the wall or into a drainage structure.

3. Geometrics

- Beginning and end of wall stations.
- Top of wall profile.
- Original and proposed ground line profiles in front of and behind the retaining wall. Profiles shall show all existing and proposed infrastructure (e.g., utilities and other existing or proposed structures) in the profile section.
- Cross sections at relevant wall locations, usually at no more than 50 feet intervals. Cross sections shall show temporary and permanent Right-Of-Way (ROW) easement limits and existing utilities.
- Plan view(s) of wall alignment showing ROW limits, existing and proposed utilities, etc.
- Wall alignment geometric data shall be shown and tabulated (similar to roadway alignment data).
- Details of foundation, leveling pad, aesthetics, or other detailed wall requirements.
- Details of wall appurtenances such as traffic barriers, moment slabs, coping, fencing, drainage, or other obstructions including but not limited to the location and configurations of signs and lighting including conduit locations and right-of-way limits.
- Construction staging requirements, if applicable, including sequence of traffic control, access, temporary construction, temporary fencing, temporary or permanent barrier, and temporary and permanent drainage.
- Elevation of highest permissible level for foundation construction.
- Location, depth and extent of any unsuitable material to be removed and replaced. Details of any required ground improvement.
- Quantities table showing estimated wall area and quantity of appurtenances and traffic barriers, together with notes identifying the assumptions made in estimating.
- At abutments, elevations of bearing pads, location of bridge seat, skew angle and all horizontal and vertical survey control data including clearance and details of abutments.
- At stream locations, extreme high water, normal water levels and estimated scour depth.
- Grading material requirements adjacent to the wall, including details of any needed perforated pipe drainage or any other drainage requirements.

4. Geotechnical information - A copy of the subsurface investigation report and specific design values for the following parameters (where required)

- Plan view of sampling, testing and boring locations across project site.
- Subsurface profile across project site.
- Boring logs.
- All laboratory test data and results.
- Engineering properties of the foundation soil, reinforced soil, and retained soil as appropriate to ensure the proper long-term performance of the MSE wall structure.
- Required soil modification.
- Global and compound stability analysis.
- Allowable and ultimate bearing pressure beneath the wall footing and the reinforced earth mass.

- Settlement analysis for the foundation soil beneath the wall and the reinforced earth mass.
- Groundwater elevations, any free water conditions, anticipated high water conditions and any required drainage schemes.
- Recommendations concerning items that may be appropriate to ensure the proper long-term performance of the wall structure.
- Shear strength (drained and undrained for fine grained soils) of foundation soils.
- Required shear strength and unit weight ranges of select backfill.
- Shear strength of random fill or in-situ soil behind wall

5. General Structural and Geotechnical Design Requirements - The following are general design requirements for retaining walls that will be shown on the drawings or addressed in the contract documents. Specific design requirements for each of the wall types are discussed in the following sections.

- o. Design Life of the structure (example: permanent mechanically stabilized earth walls are designed, for minimum corrosion service life of 100 years)
- p. Driving force and resistance for overturning, sliding and stability of temporary construction slopes. Analysis for global and compound stability is performed by Foundation Unit.
- q. Ultimate and nominal foundation bearing pressure, minimum wall footing embedment depth and maximum tolerable total and differential settlements.
- r. Internal design requirements for mechanically stabilized earth wall products.
- s. Magnitude, location and direction of external loads due to bridge, overhead signs and lights, traffic surcharge and rapid ground water draw down or displacements and any other external loads.
- t. Limits and requirements for drainage features beneath, behind, or through retaining structure.
- v. Backfill requirements for both within and behind retaining structure.
- w. Requirements for special facing panels, module finishes, colors, and/or protective coatings.
- X. Governing sections of construction specifications.