

UBSP ASSEMBLY

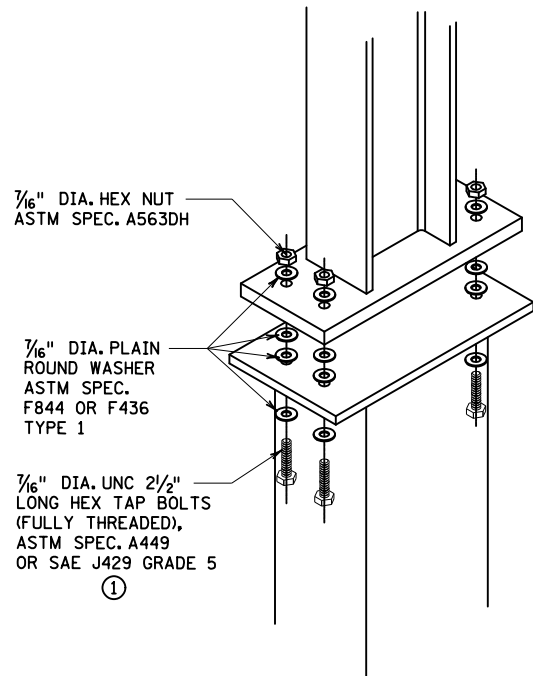

UBSP ASSEMBLY HARDWARE

NOTES:

- GALVANIZE ALL HARDWARE PER ASTM A153.
- ① TORQUE TO APPROXIMATELY 60-75 FT-LB.

APPROVED 04-11-2021

Rom S. J.
STATE DESIGN ENGINEER

STATE OF MINNESOTA
DEPARTMENT OF TRANSPORTATION

UNIVERSAL BREAKAWAY STEEL POST
(UBSP)

SPECIFICATION
REFERENCE

3306
3394

STANDARD
PLATE
NO.

8362A

1 OF 2

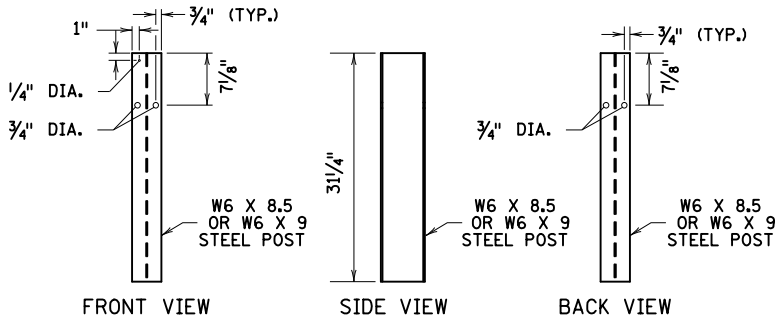

UPPER POST ①

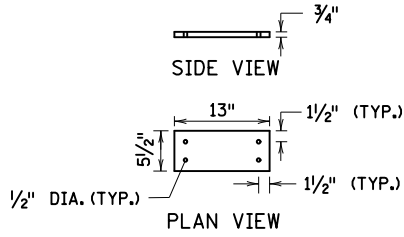

UPPER SHEAR PLATE ①

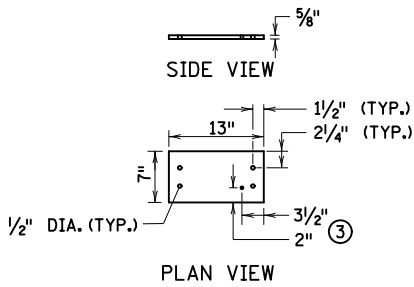

LOWER SHEAR PLATE ①

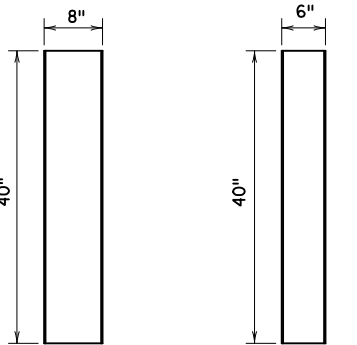
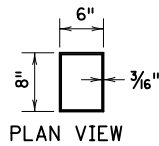

LOWER POST ②

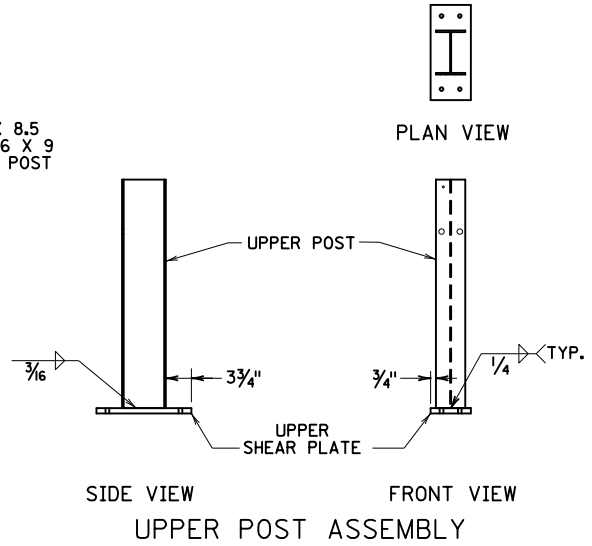

UPPER POST ASSEMBLY

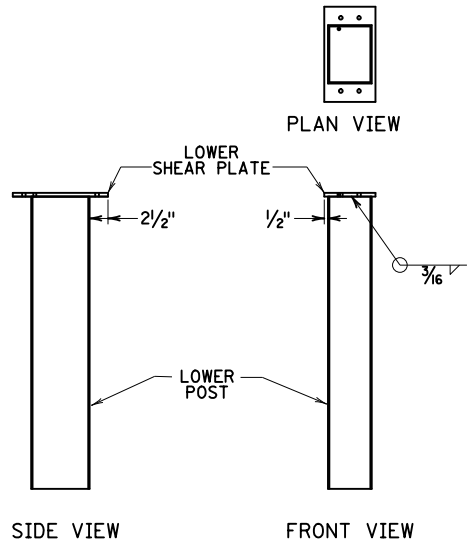

LOWER POST ASSEMBLY

- NOTES:
 GALVANIZE ALL COMPONENTS PER ASTM A123.
 ① SPECIFICATION PER ASTM A36.
 ② SPECIFICATION PER ASTM A500, GRADE B.
 ③ 3/8" DIA. WEEP HOLE FOR DRAINING OF HOT ZINC COATING DURING THE GALVANIZATION PROCESS.

APPROVED 04-11-2021

Ron Sja
 STATE DESIGN ENGINEER

STATE OF MINNESOTA
 DEPARTMENT OF TRANSPORTATION

UNIVERSAL BREAKAWAY STEEL POST
 (UBSP)

SPECIFICATION
 REFERENCE

3306
 3361
 3394

STANDARD
 PLATE
 NO.

8362A
 2 OF 2