

COMMERCIAL - INDUSTRIAL - FARM ENTRANCES

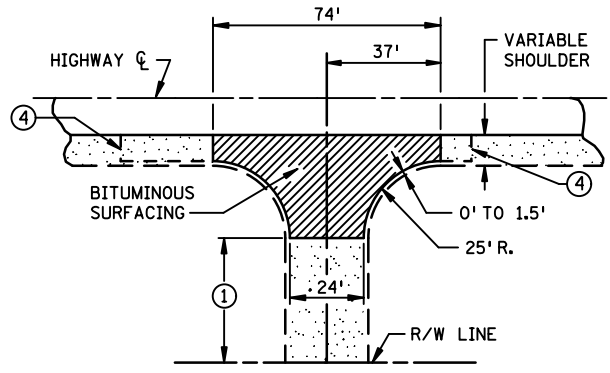

RURAL RESIDENTIAL ENTRANCE

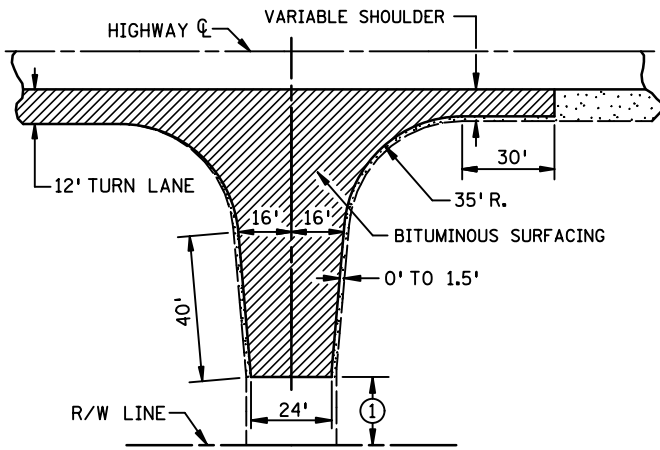

LOW VOLUME ROAD

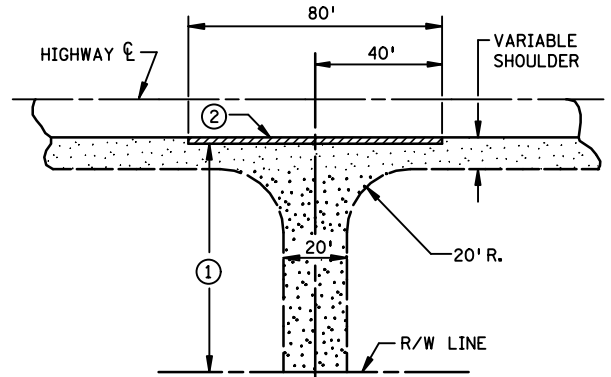

FIELD ENTRANCES

- ① SURFACING TO MATCH EXISTING CONDITIONS. WHERE THERE IS NO SURFACING, PLACE GRAVEL BEYOND BITUMINOUS SURFACING TO R/W LINE.
- ② PLACE 2 FT. WIDE BITUMINOUS SURFACING AS DIRECTED BY ENGINEER.
- ③ 8% MAXIMUM COMMERCIAL; 15% MAXIMUM RESIDENTIAL.
- ④ THE USE OF PAVING SIMILAR TO COMMERCIAL ENTRANCES MAY BE APPROPRIATE FOR SOME RESIDENCES - AS SHOWN IN PLANS OR DIRECTED BY THE ENGINEER.

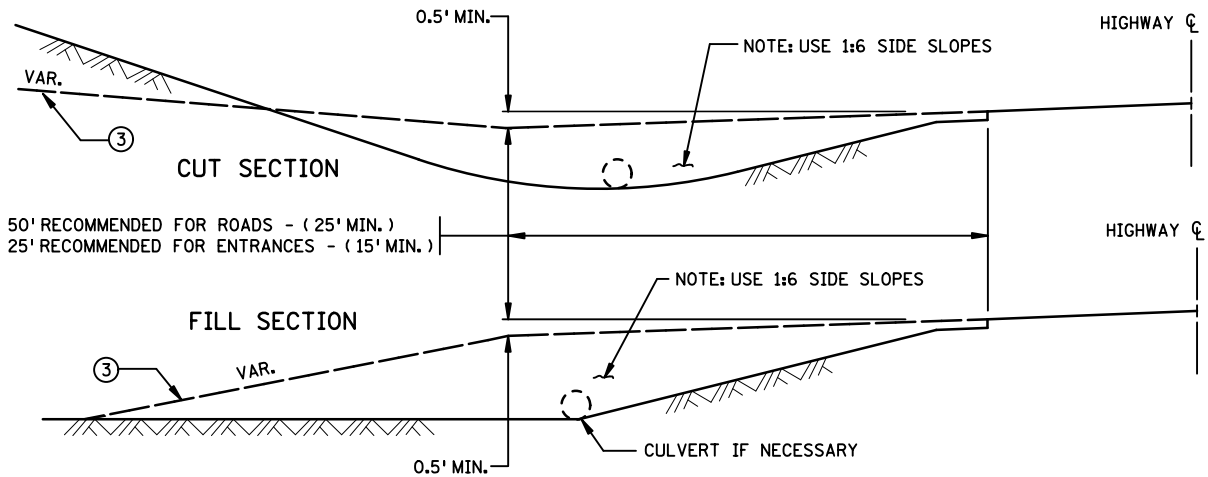

CROSS SECTIONS

APPROVED SEPT. 27, 2012

*Michael J. Henneman*  
STATE DESIGN ENGINEER

STATE OF MINNESOTA  
DEPARTMENT OF TRANSPORTATION

APPROACHES AND ENTRANCES  
RECOMMENDED STANDARDS

SPECIFICATION  
REFERENCE

STANDARD  
PLATE  
NO.

9000E