CHAPTER 6
INTERCHANGES AND GRADE SEPARATIONS

6-1.0 GENERAL

6-1.01 Definitions

6-1.02 Warrants

6-1.03 Types of Interchanges

- 6-1.03.01 General
- 6-1.03.02 Three-Leg
- 6-1.03.03 Diamond Interchanges
- 6-1.03.04 Cloverleaf Interchanges
- 6-1.03.05 Directional and Semi-Directional Interchanges
- 6-1.03.06 Comparing Interchange Forms

6-1.04 Concept Development

- 6-1.04.01 General
- 6-1.04.02 Capacity
- 6-1.04.03 Selection of Interchange Type
- 6-1.04.04 Distance Between Interchanges
- 6-1.04.05 Distance Between Successive Ramp Terminals
- 6-1.04.06 Crash Potential

6-1.05 Number of Lanes Through an Interchange

- 6-1.05.01 General
- 6-1.05.02 Basic Number of Lanes
- 6-1.05.03 Lane Balance
- 6-1.05.04 Auxiliary Lanes
- 6-1.05.05 Escape Lanes

6-1.06 Right-of-Way and Access Control

- 6-1.06.01 Expressway On-Ramps

6-2.0 RAMP-FREEWAY AND RAMP-STREET JUNCTIONS (TERMINALS)

6-2.01 General

6-2.02 Sight Distance

6-2.03 Exit Ramp Design

- 6-2.03.01 Deceleration Lanes (Tangent Mainline)
- 6-2.03.02 Deceleration Lanes (Left-Curving Mainline)
- 6-2.03.03 Gore Area

6-2.04 Entrance Ramp Design

- 6-2.04.01 Acceleration Lanes
- 6-2.04.02 Gore Areas

6-2.05 Multi-Lane Exits and Entrances

- 6-2.06 Weaving
- 6-2.07 Ramp Controls
 - 6-2.07.01 Policy
- 6-2.08 Metered Ramps
 - 6-2.08.01 System-to-System Metered Ramps
 - 6-2.08.02 Operational Criteria
 - 6-2.08.03 Design Details
- 6-2.09 High Occupancy Vehicle (HOV) Ramp Bypass Lanes
 - 6-2.09.01 HOV Bypass Design Criteria

6-3.0 RAMP DESIGN

- 6-3.01 Policy (Urban/Rural)
- 6-3.02 Types
 - 6-3.02.01 Diagonal
 - 6-3.02.02 Loops
 - 6-3.02.03 Semi-Direct
 - 6-3.02.04 Direct
- 6-3.03 Capacity
- 6-3.04 Design Elements
 - 6-3.04.01 Design Speed
 - 6-3.04.02 Horizontal Alignment
 - 6-3.04.03 Vertical Alignment
 - 6-3.04.04 Cross Section

6-4.0 RAMP AND MINOR ROAD JUNCTION

- 6-4.01 General
- 6-4.02 Frontage Road Intersections

6-5.0 COLLECTOR-DISTRIBUTOR (C-D) ROADS

- 6-5.01 General

6-6.0 MAJOR FORKS (DIVERGES)

- 6-6.01 Application
- 6-6.02 Design of Major Forks
 - 6-6.02.01 Major Forks on Freeways with 2 or 3 Basic Lanes Prior to the Diverge
 - 6-6.02.02 Major Forks on Freeways with 4 or 5 Basic Lanes Prior to the Diverge
 - 6-6.02.03 Lane Drop Guidelines at Major Forks

6-7.0 BRANCH CONNECTIONS (MERGES)

- 6-7.01 Application

CHAPTER 6 INTERCHANGES AND GRADE SEPARATIONS

6-1.0 GENERAL

6-1.01 Definitions

An interchange is a system of interconnecting roadways in conjunction with one or more grade separations that provide for the movement of traffic between two or more roadways on different levels. The purpose of an interchange is to provide turning drivers an efficient and safe method for changing directions without hindering the flow of the through movement on the mainline, and in the case of system interchanges, on both roadways.

A system interchange is an interchange between two or more freeways or controlled access facilities. Examples include directional and full cloverleaf interchanges.

A service interchange is an interchange between a freeway or controlled access facility and a lower class roadway such as an arterial or collector. Examples include diamond and partial cloverleaf interchanges.

6-1.02 Warrants

An interchange is the ultimate solution to intersection problems; however, its very high cost and right of way and environmental impacts require that interchanges be limited to sites where they are justified. Because of the great variance in specific site conditions, rigid warrants cannot be established. However, the following offer sound guidelines for review of the interchange need:

1. Once a decision has been made to provide a fully access-controlled facility, no at-grade intersections can be allowed. For each intersecting road, it must then be decided whether to terminate, reroute, provide a grade separation, or provide an interchange with the freeway. The access that some roads provide cannot reasonably be closed, so part of the decision has been made. A rough rule-of-thumb is that if the traffic volumes of the freeway and crossing road are high enough that a hypothetical at-grade intersection would warrant a traffic signal, then a grade separation or interchange is indicated.
2. An interchange may be warranted if the congestion at an at-grade intersection is intolerable, and the intersection cannot be redesigned to accommodate the traffic volumes. Therefore, when the capacity of an intersection is exceeded, a cost-effective analysis should be conducted to determine the warrant for an interchange. See Section 2-4.03 "Cost-Effectiveness".
3. If a serious safety hazard exists at an at-grade intersection, a cost-effective analysis may justify the expense of an interchange solely on the basis of safety benefits. See Section 2-4.03.
4. Occasionally, the topography of a site may be such that an interchange can be constructed at less than or comparable to the cost of an at-grade intersection.
5. The general criteria for interchange spacing must be considered. It is possible that an intersecting road which would otherwise warrant an interchange can only be provided a grade separation. In general, interchanges in urban areas should be spaced at a minimum of about 1 mile intervals and at much larger intervals in rural areas. The minimum allowable distance actually provided along an arterial will be determined by a consideration of weaving volumes, ability to sign, and required lengths of speed-change lanes. In addition, the level of service requirements, as discussed in the next section, must be met.

Chapter 10 of AASHTO's A Policy on Geometric Design of Highways and Streets provides 6 warrants for interchanges. Designers may refer to those for guidance.

6-1.03 Types of Interchanges

6-1.03.01 General

The figures in this section illustrate several standard interchange forms. Each form can vary extensively in shape and scope, and there are numerous combined forms that cannot be designated by separate names. It is important to remember that each interchange form has advantages and disadvantages relative to alternative forms. There is no one clearly superior form. Individual site conditions should determine the selected form.

6-1.03.02 Three-Leg

Three-leg interchanges or T-interchanges are provided at intersections with three legs. Figure 6-1.03A illustrates four examples. The turning movements may be provided with ramps, loops, or both. Interchanges "A" and "B" in the figure are of the trumpet variety and are more commonly used. Because of the presence of loops in

consecutive quadrants in Interchange C, weaving will occur (see discussion on weaving in Section 6-1.03.04). Interchange "C" may be used when turning volumes are light and neither "A" nor "B" is adaptable to the site. When turning volumes are high or a freeway-to-freeway connection is to be provided, the fully directional design in "D" may be considered. However, this design is considerably more costly than either of the other three because of the multilevel structure required. And, because of the multi-levels, they have a bigger visual impact, and use up more ROW.

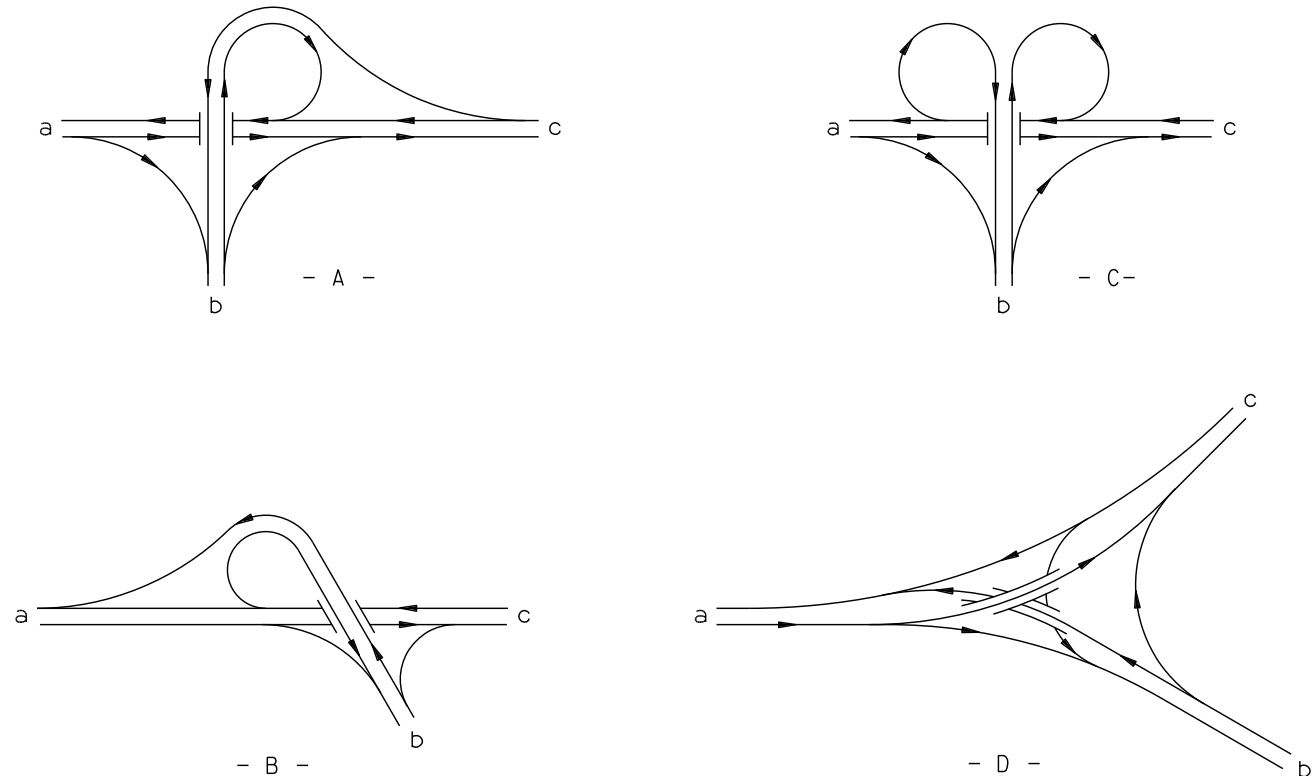

THREE-LEG INTERCHANGES

Figure 6-1.03A

6-1.03.03 Diamond Interchanges

Diamond interchanges are the least expensive form of interchange due to the relatively small right of way they use and the ease of design and construction. This makes diamond interchanges the most common service interchange form used. On the other hand, diamond interchanges result in at least one 90 deg intersection, thus requiring signal or sign control. There are several different forms of diamond interchanges that are highly adaptable to different ranges of traffic volumes.

A. General Use Diamonds (See Figure 6-1.03B)

All of these forms can have frontage roads. See figure for examples.

1. Conventional Diamond

Conventional diamond (diamond) interchanges are characterized by a one-way diagonal ramp in each quadrant with two at-grade intersections on the minor road. The at-grade intersections may be stop signed or signal controlled. This interchange form allows easy accommodation of pedestrian crossings of the minor road.

2. Compressed Diamond

Same form as the conventional diamond. The spacing between the two at-grade intersections is usually between 400 and 700 feet. One or both of the intersections may be unsignalized. To mainline traffic, compressed diamonds are similar in appearance and operation to conventional diamonds. This interchange form allows easy accommodation of pedestrian crossings of the minor road.

3. Split Diamond

Split diamonds serve multiple minor roads connected by frontage roads that are usually one-way. Split diamonds offer two advantages. One: reducing conflicts by handling traffic at four, rather than two, intersections. Second: reducing the left-turn movements at each intersection from two to one. The disadvantage of this form is that it is more costly (two bridges). This form of interchange is most appropriate in busy urban areas such as Central Business Districts. This interchange form allows easy accommodation of pedestrian crossings of the minor road.

4. Folded Diamond

Also called Parclo AB. See discussion in Section 6-1.03.04.

B. High Capacity Diamond Interchanges**1. Diamonds with Flyovers**

One or more of the heavy left turn movements are served via a directional or semi-directional ramp (flyover). This increases the efficiency by allowing the heavy left turn movement to flow without stopping. On the other hand, using flyovers increases cost and right of way needs.

2. Three Level Diamonds

Connections between the two roadway systems are made via a different (3rd) level and four pairs of ramps. This provides for uninterrupted through movement on both of the intersecting roadways. Only the left-turning movements cross at grade. The amount of required right of way for a three level diamond interchange is smaller than other forms having comparable capacity. On the other hand, three level diamonds are very expensive, and therefore not commonly used in Minnesota. Due to the multi-levels, they have a big visual impact. Refer to AASHTO's [Policy on Geometric Design of Highways and Streets](#) for design details.

C. Diamond Interchanges for Constrained Locations**1. Single Point Diamond Interchange (SPDI)**

Also known as single point urban interchange (SPUI) or urban interchange (UI). SPDIs have only one at-grade intersection on the minor road. See Figure 6-1.03C.

- a. Because of the complexity of their geometry, SPDIs shall be signalized (3-phase signal), and all left turn movements shall be fully protected. Because there is only one signal, SPDIs allow easier coordination of the signals on the minor road leading to less delay for the minor road through movement.
- b. SPDIs use less right of way than regular diamonds or cloverleaves.
- c. The form of an SPDI makes it necessary to use longer bridges and more retaining walls than other diamonds. Therefore, SPDI cost 20 to 25% more than conventional diamonds.
- d. The bridges and retaining walls increase the cost of widening an existing interchange substantially over that of other diamonds. Therefore, the initial design of an SPDI should have double turn lanes for all left-turn movements.
- e. SPDIs are designed to allow high volumes of left turns from the off ramp to flow at relatively high speed and with minimum delays. The geometry of the SPDI is shaped to facilitate that. To provide adequate visibility and the high speed left turns, SPDIs use large turning radii (150 to 300 ft) for the off ramps. Consequently, the distance between the stop bars on the minor road can exceed 200 or 250 ft. Studies have shown that the operational advantages of SPDIs diminish as that distance increases.
- f. This large distance creates the need for positive guidance (extra lane markings and raised median) to keep left turning vehicles from straying from their proper path.
- g. SPDIs should be avoided if the two roadways intersect at a large skew angle. Large skew angles reduce the visibility of the intersection and further increase the distance between the stop bars on the minor road thus increasing bridge length.
- h. SPDIs should physically separate the off-ramp left and rights turns and allow the right turn to flow independent of the signal. This will significantly decrease the green time needed for the off ramp and the overall delay.
- i. Attaching a frontage road to the SPDI should be avoided as it will necessitate adding a fourth phase to the signal thus significantly increasing the overall delay.

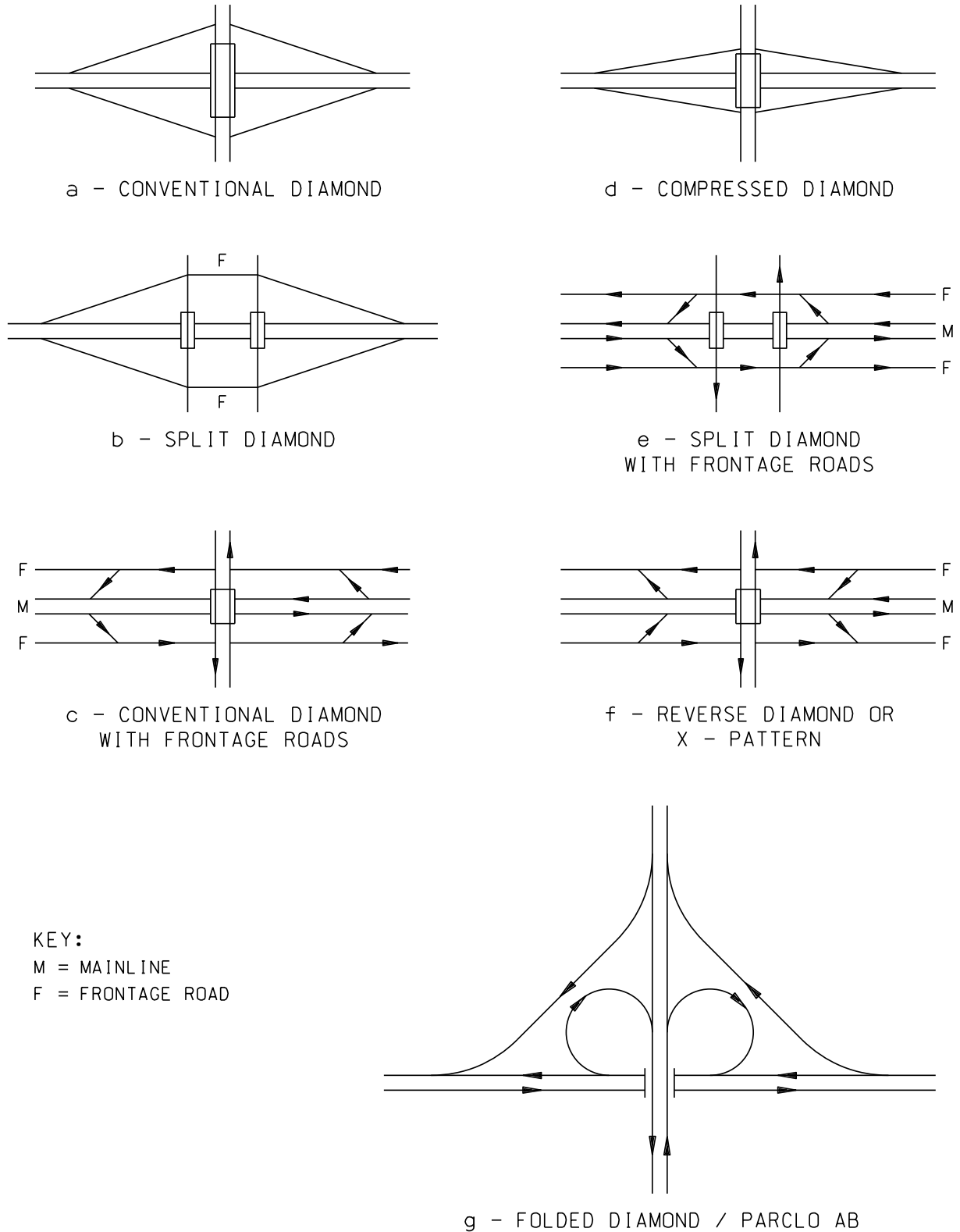

DIAMOND INTERCHANGES
Figure 6-1.03B

- j. Because of the unique signal and sign requirements of this type of interchange, constructing the minor road to go over the mainline is preferable; the intersection is more visible, less lighting is needed, and the signal/sign placements are not influenced by the bridge structure. At SPDI with the minor road going under the mainline, an additional vertical clearance is needed to place signal heads, and the size of the bridge and amount of retaining walls (mainline, not minor road, is bridged) also increase.
- k. The form and signal phasing of an SPDI do not allow easy accommodation of pedestrian crossings of the minor road. One option is to ban pedestrians from crossing the minor road at the SPDI signal. Another option is to allow pedestrians to cross to the raised median during the off-ramp phase, and then cross the other half during the minor road left turn phase. Adding a pedestrian phase to the SPDI signal significantly increases the overall delay of the interchange and should be avoided if possible.
- l. Although some agencies indicated that there was confusion at SPDIs just after they were opened to traffic, national studies have shown that driver unfamiliarity with SPDIs is not a major factor in crash occurrence in the interchange area. The predominant crash type at SPDIs is rear-end crashes on the off-ramp. This is consistent with the geometry of SPDIs where large turn radii are provided to allow a high speed left-turn from the off ramp. If not designed properly, drivers may not be able to see the signal head until they are near the stop line.

Because of their high cost, SPDIs should only be used where necessitated by the characteristics of the site (restrictive right of way or very close spacing to adjacent intersections on the minor road), or where they will provide substantial operational advantages over other interchange forms. If special features (pedestrian phase, frontage road, skew angle, highly directional minor road through movement, etc.) have to be accommodated within the interchange, the operational benefits of SPDIs are severely decreased. In such cases, other interchange forms are more appropriate.

2. Tight Diamond Interchange (TDI)

Same form as the conventional diamond. The spacing between the two at-grade intersections is usually between 250 and 400 feet. To mainline traffic, tight diamonds are similar in appearance and operation to conventional diamonds. This form allows easy accommodation of pedestrian crossings of the minor road.

Because of the close spacing between the intersections, both must be signalized, and the signals must be coordinated to allow through traffic to pass through both intersections with, at the most, one stop. Furthermore, to get maximum operational efficiency, special treatment of channelization and traffic control is required: left turns from the minor road must store in advance of the first intersection (not between the two ramps). This may make this type of interchange more susceptible to wrong-way movements.

NCHRP Report 345: "It may appear ironic that tight urban diamond interchanges having spacing of 250 to 350 ft can operate better than wider compressed diamonds with spacing between signals of 500 to 600 ft. This reality is believed to be not well known by some highway engineers and planners. Two requirements must be met to achieve this level of operational performance, however. One is that the ramp spacing should be in the range of 250 to 400 ft. Second is that only one traffic-actuated signal controller should be used, and it must be designed and timed properly to best satisfy existing conditions. With these design specifications, TDI is a viable alternative to all other interchange forms in the two-level signalized urban interchange class."

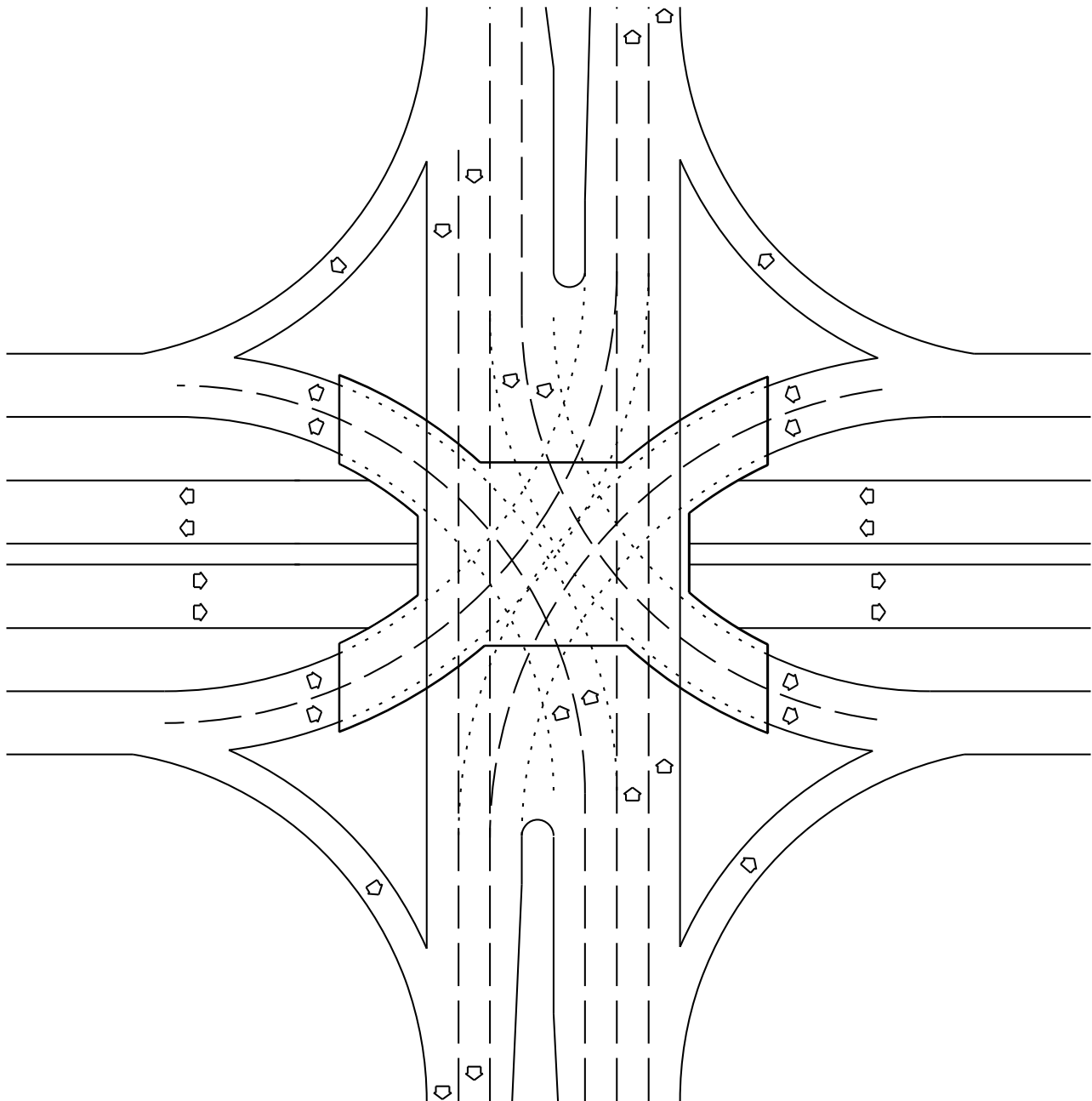
**SINGLE POINT DIAMOND INTERCHANGE****Figure 6-1.03C****Comparing TDI and SPDI**

1. NCHRP 345: "The SPDI and TDI should both be considered viable design options for many types of urban traffic congestion relief projects where signalized intersections are involved."
2. The design of SPDIs allows left-turns from the off ramp to proceed at higher speed and with less delay than with TDIs. In handling left turns to the on ramps, neither form has a clear advantage over the other.
3. TDIs cause less delay (than SPDIs) to the minor road through movements. TDIs are better at handling high directional splits in the minor road through movements.
4. Capacity analyses have determined that, overall, SPDIs are slightly more efficient than TDIs. The advantage diminishes as SPDIs become larger.

5. The efficiency of a TDI increases with the increase of the distance between ramps. The efficiency of the SPDI decreases with the increase of the distance between ramps. For distance between ramps of 250 to 275 ft, the operational efficiencies of the TDI and SPDI are equivalent on a per lane basis.
6. There is no clear safety difference between the TDI and SPDI.
7. Pedestrians are more difficult to accommodate at SPDI.
8. Construction costs of a TDI are between 15 and 25% less than those of a SPDI and use only slightly more right of way than SPDI. Therefore, TDI are appropriate alternatives to SPDI.

6-1.03.04 Cloverleaf Interchanges

Cloverleafs use loops to accommodate some/all of the left turn movements thus eliminating the need for one or more intersection/stop on the minor road. This decreases the delay encountered by these movements and increases the efficiency of the overall interchange. On the other hand, loops require more right of way than ramps and are more susceptible to run off the road accidents. The speed of travel on a loop may be increased by using larger loop radii. This, however, must be weighed against the disadvantage of increased right of way.

Partial cloverleafs (Parclo) result in at least one 90-degree intersection, thus requiring signal or sign control. With full cloverleafs, because all the left turn movements are made via loops, there is no need for any intersections.

In full cloverleafs, Parclo AB, and 3-loop Parclo, because loops are present in adjacent quadrants, weaving is a problem that may lead to a breakdown in traffic operation and more accidents. AASHTO estimates that when the sum of traffic on two consecutive loops approaches 1000 vph, the Level of Service starts to deteriorate. In such cases, if other interchange forms cannot be used, collector-distributor (C-D) roads should be strongly considered, see Section 6-5.0.

Full Cloverleafs

Because of the weaving problems, full cloverleafs are considered the minimum system interchange type. Therefore, full cloverleafs should not be used in high traffic volume areas. Because of the four loops, full cloverleafs use up very large amounts of right of way. See Figure 6-1.03D.

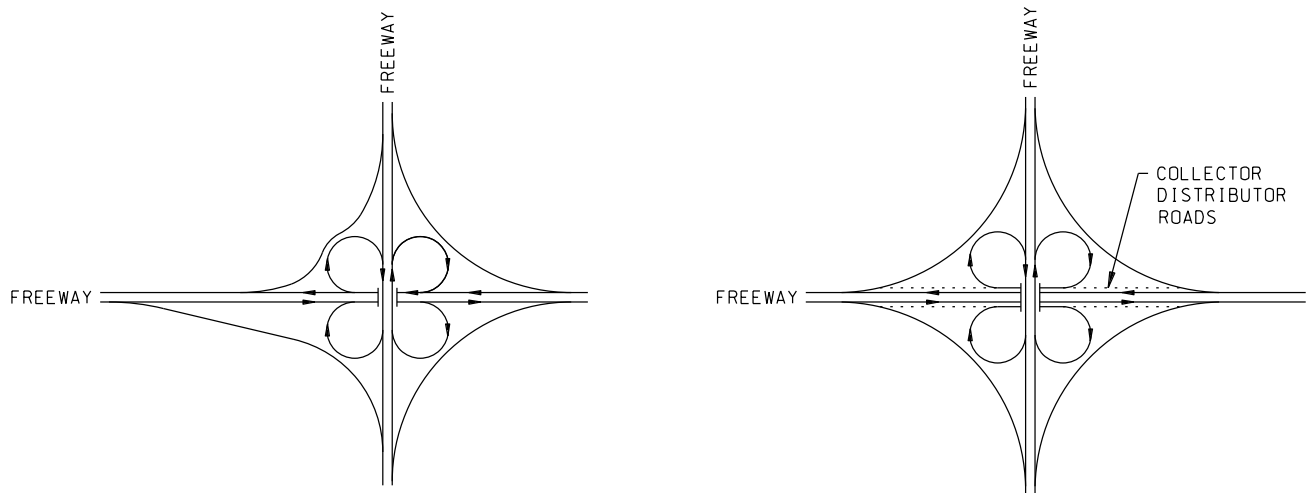

FULL CLOVERLEAFS

Figure 6-1.03D

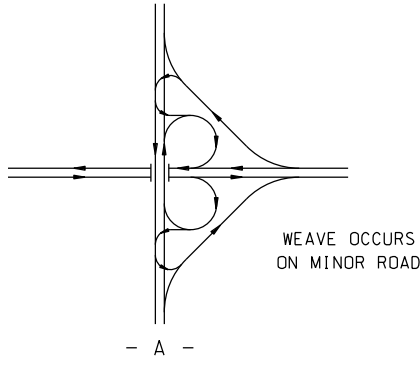

PARCLO AB / FOLDED DIAMOND
ON BOTH SIDES OF MAJOR ROAD
LEFT TURNS: NONE ON MAJOR ROAD
4 ON MINOR ROAD

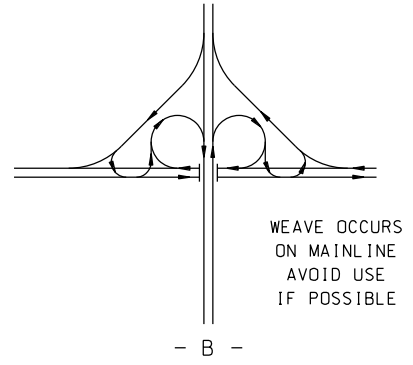

PARCLO AB / FOLDED DIAMOND
ON SAME SIDE OF MAJOR ROAD
LEFT TURNS: 4 ON MAJOR ROAD
NONE ON MINOR ROAD

TWO QUADRANTS: ADJACENT

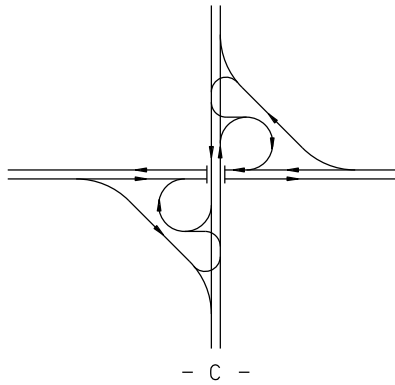

PARCLO A
MAJOR ROAD EXITS ON NEAR SIDE
LEFT TURNS: NONE ON MAJOR ROAD
4 ON MINOR ROAD

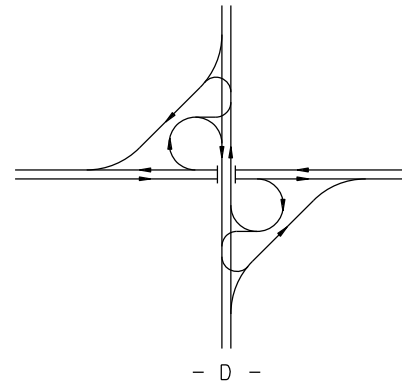

PARCLO B
MAJOR ROAD EXITS ON FAR SIDE
LEFT TURNS: NONE ON MAJOR ROAD
4 ON MINOR ROAD

2 QUADRANTS: DIAGONALLY OPPOSITE

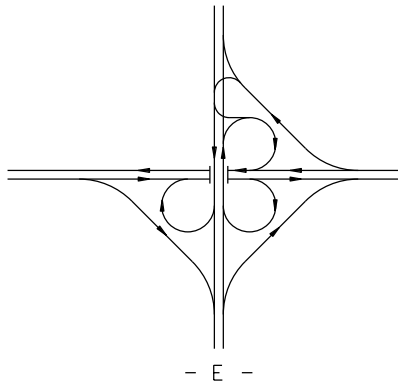

2 MAJOR ROAD EXITS ON NEAR SIDE,
ONE ON FAR SIDE
LEFT TURNS: NONE ON MAJOR ROAD
2 ON MINOR ROAD

3 QUADRANTS

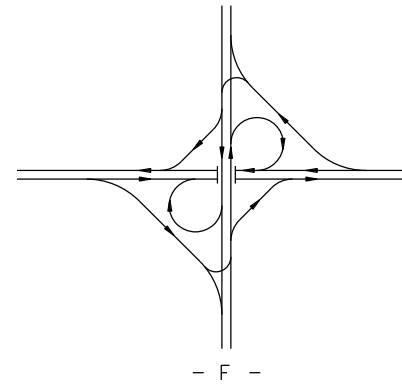

MAJOR ROAD EXITS ON NEAR SIDE
LEFT TURNS: NONE ON MAJOR ROAD
2 ON MINOR ROAD

4 QUADRANTS

PARTIAL CLOVERLEAF (PARCLOS) RAMP ARRANGEMENTS
Figure 6-1.03E

Partial Cloverleaves (Parclos)

Parclos use one, two, or three loops for left turn movements, see Figure 6-1.03E. The heavier left turn movements are the ones accommodated via loops. Parclos are highly adaptable and can accommodate high traffic volumes. They are especially advantageous when one or more quadrants must be avoided due to right of way restrictions.

Two Loop Parclos

Two loop Parclos are divided into the following 3 categories. For all 3 categories, the distance between intersections is usually between 600 and 900 ft.

A. Parclo A

In Parclo A interchanges, exits from the mainline are made via ramps. Mainline entrances can be made via loops in a 2-quad. Parclo A (see Figure 6-1.03F) or via loops and ramps in a 4-quad. Parclo A (see Figure 6-1.03G). With either form of Parclo A, minor road through traffic has to stop twice. Each stop is usually controlled by a 2-phase signal. 4-quad. Parclo A is the only Parclo form that provides right turn movements for all mainline exit and entrance movements. From an overall interchange's view, 4-quad. Parclo A is the highest capacity service interchange form.

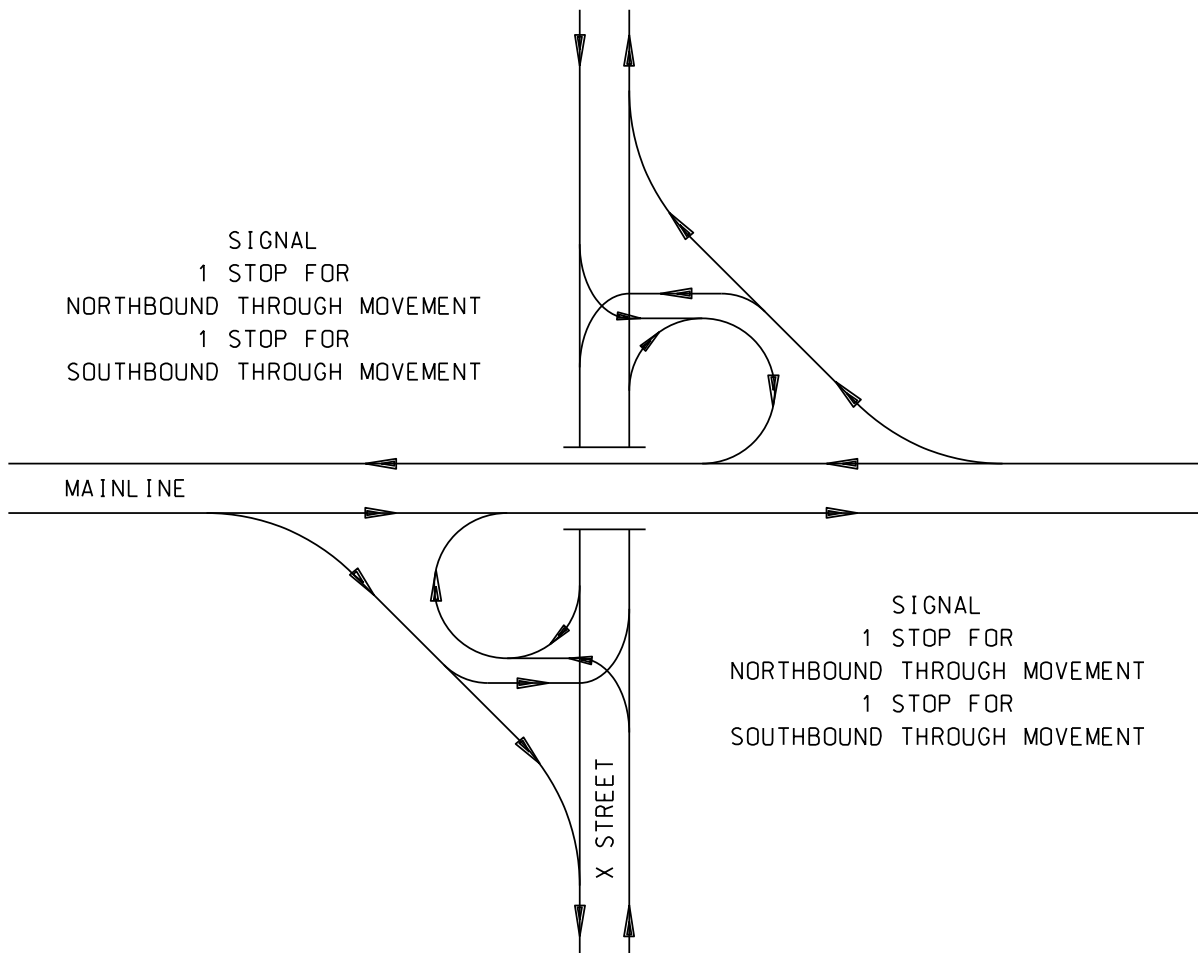

PARCLO A – 2 QUAD. (EXIT RAMPS, ENTRANCE LOOPS)

Figure 6-1.03F

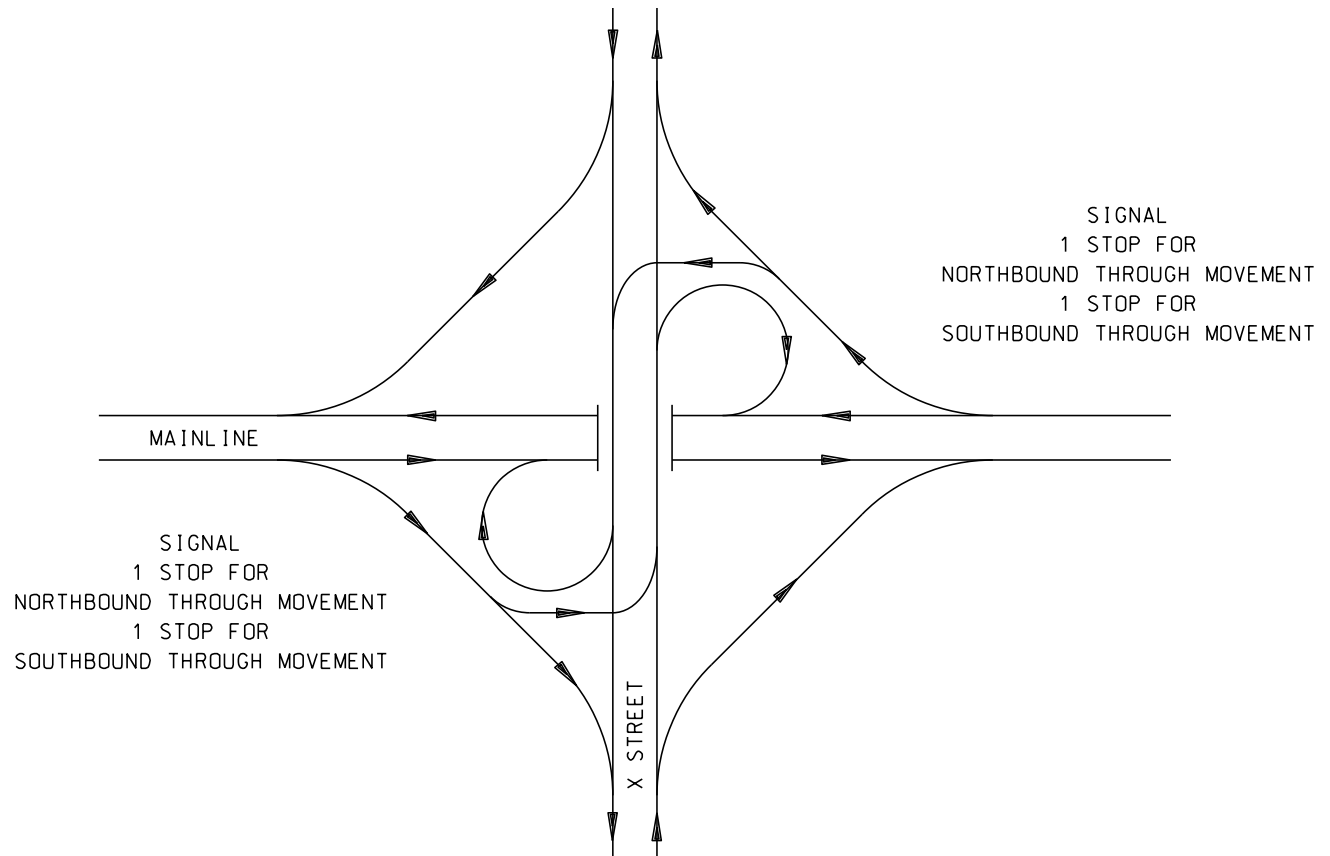

PARCLO A – 4 QUAD. (EXIT RAMPS, ENTRANCE LOOPS AND RAMPS)

Figure 6-1.03G

B. Parclo B

In Parclo B interchanges, entrances to the mainline are made via ramps. Mainline exits can be made via loops in a 2-quad. Parclo B (see Figure 6-1.03H) or via loops and ramps in a 4-quad. Parclo B (see Figure 6-1.03I). In 2-quad. Parclo B, minor road through traffic has to stop twice. Each stop is usually controlled by a 2-phase signal. In 4-quad. Parclo B, minor road through traffic has to only stop once. Thus, from the minor road's view, 4-quad. Parclo B provide the highest capacity. This one stop, however, makes it more difficult for pedestrians to cross the minor road.

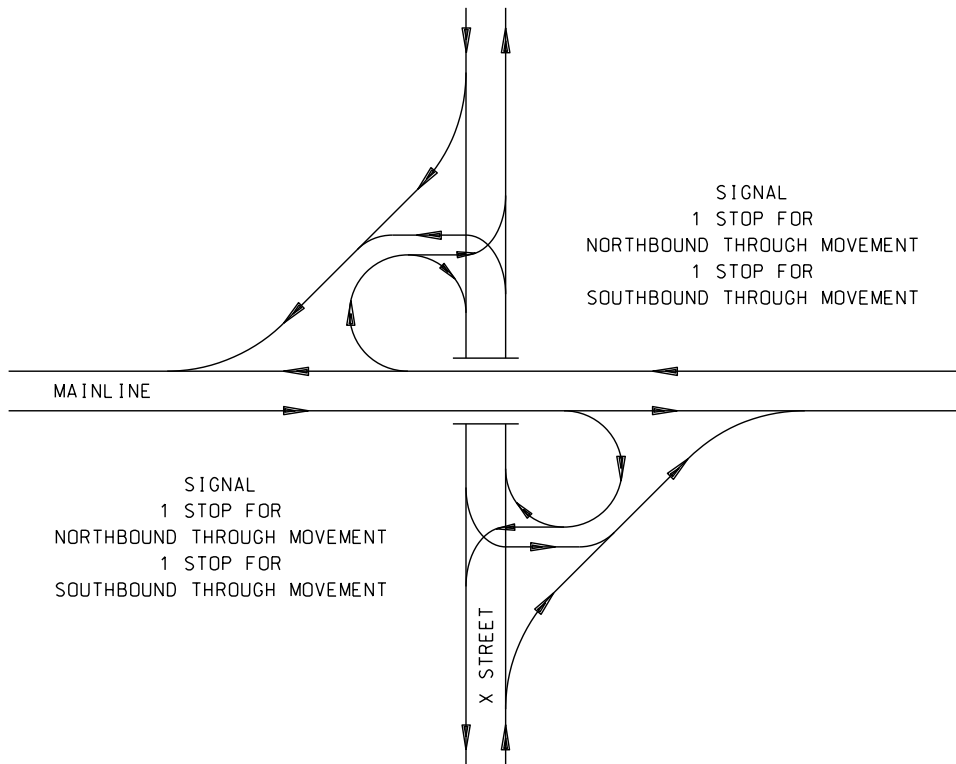

PARCLO B – 2 QUAD. (EXIT LOOPS, ENTRANCE RAMPS)
Figure 6-1.03H

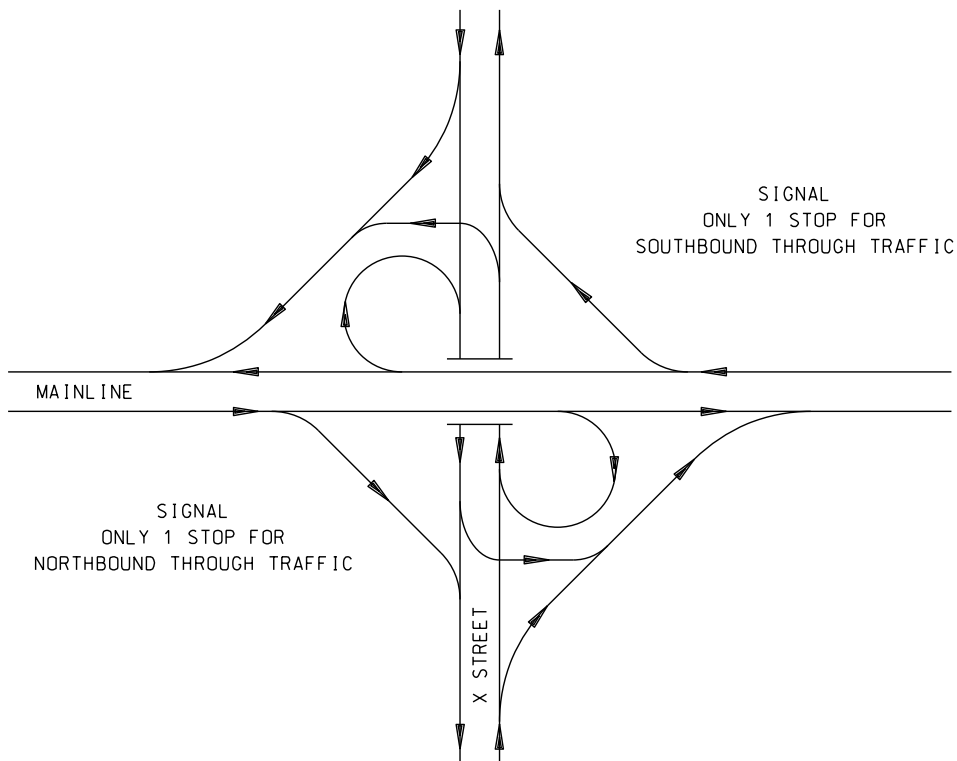

PARCLO B – 4 QUAD. (ONE EXIT LOOP, ONE EXIT RAMP, ENTRANCE RAMPS)
Figure 6-1.03I

C. Parclo AB or Folded Diamond

Parclo AB/folded diamond interchanges have one exit loop, one exit ramp, one entrance loop, and one entrance ramp (see Figure 6-1.03J). In Parclo AB, minor road through traffic has to stop twice. Each stop is usually controlled by a 2-phase signal. Because the loops are in two consecutive quadrants, weaving is a problem. The loops should be oriented so that the weave occurs on the minor road (not the mainline), and so that the turning movements provide the least possible disruption to mainline traffic. See Figure 6-1.03E, parts A and B, as well as AASHTO's detailed discussion. To avoid wrong way movements on folded diamond interchanges, channelization should be strongly considered.

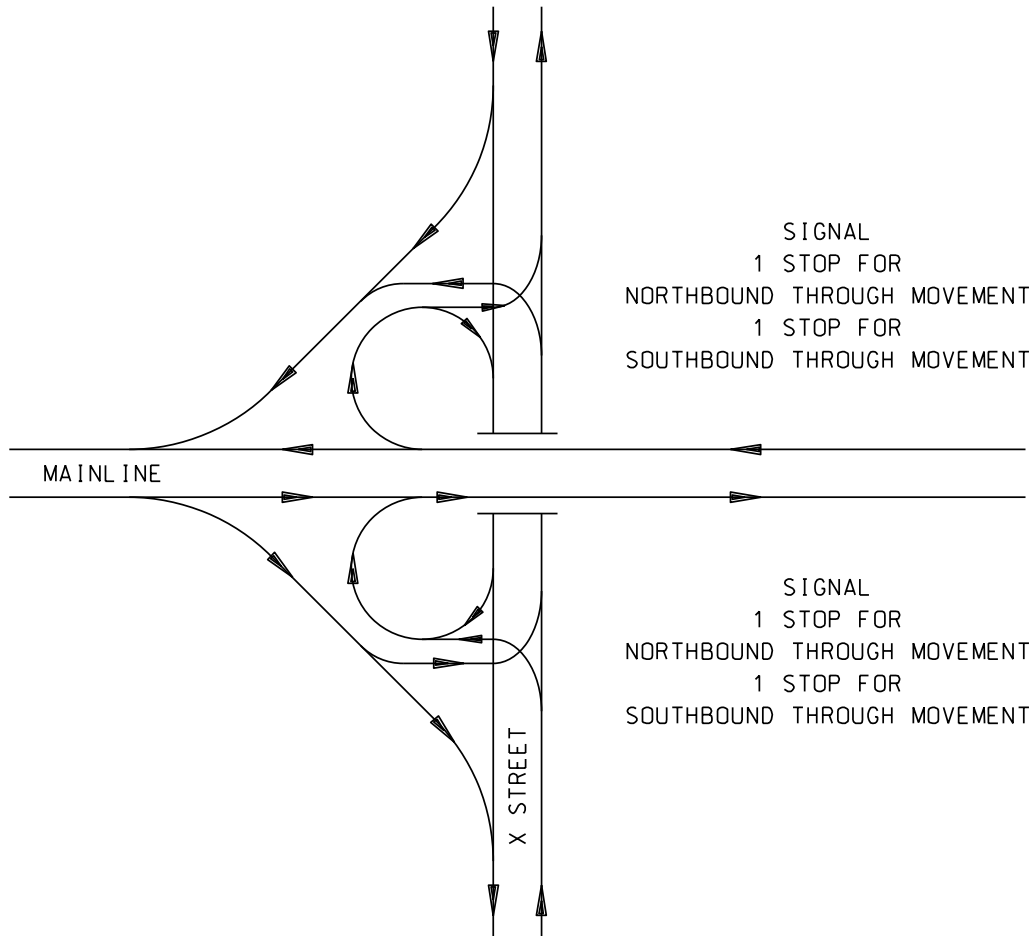

**PARCLO AB/FOLDED DIAMOND
(ONE EXIT LOOP, ONE EXIT RAMP, ONE ENTRANCE LOOP, ONE ENTRANCE RAMP)**

Figure 6-1.03J

Comparing Parclo, Conventional Diamond and SPDI

Studies have shown that Parclo signalized delays are significantly less than those of diamonds or SPDIs for all entering volumes. This is due to the fact that large left-turning movements are serviced by loops, and do not factor into the phasing systems at signalized intersections.

6-1.03.05 Directional and Semi-Directional Interchanges

Note the following definitions, see Figures 6-1.03K and L:

1. Direct Connection – A one-way roadway that does not greatly deviate from the intended direction of travel.
2. Directional Interchange – An interchange where one or more left-turning movements are provided by direct connection, even if the minor left-turn movements are accommodated on loops.
3. Semi-Directional Interchange - An interchange where one or more left-turning movements are indirect in alignment yet more direct than loops, even if the minor left-turn movements are accommodated on loops.
4. Fully Directional Interchange – An interchange where all left turn movements are provided by direct connections. They require 4-level structures.

Left hand exits and entrances are undesirable on directional and fully directional interchanges, but may be unavoidable due to the nature of the direct connection. The left hand exit should be designed as a major fork (discussed later in this chapter).

Directional ramps, as compared with loops, have: shorter travel distances, higher speeds of operation, higher level of service, greater capacity and operational efficiency, and no weaving. They are, however, more costly.

Directional interchanges often require less right of way than a cloverleaf design. Their primary disadvantage is increased cost because of the need for multiple-level structures. Directional interchanges are warranted in certain urban areas where traffic volumes are very high and high speed maneuvering is desired. Freeway-to-arterial connections may occasionally warrant a directional interchange.

Semi-directional interchanges offer the same advantages but to a lesser degree, and they may or may not eliminate weaving.

Fully directional interchanges offer the highest capacity of all interchange forms. On the other hand, they are the most expensive of all interchange forms. Therefore, fully directional interchanges are only justified for freeway to freeway connections where high turn volumes exist in all directions, and high speed uninterrupted flow is needed. Fully directional interchanges are only warranted after an in-depth assessment of their costs and benefits.

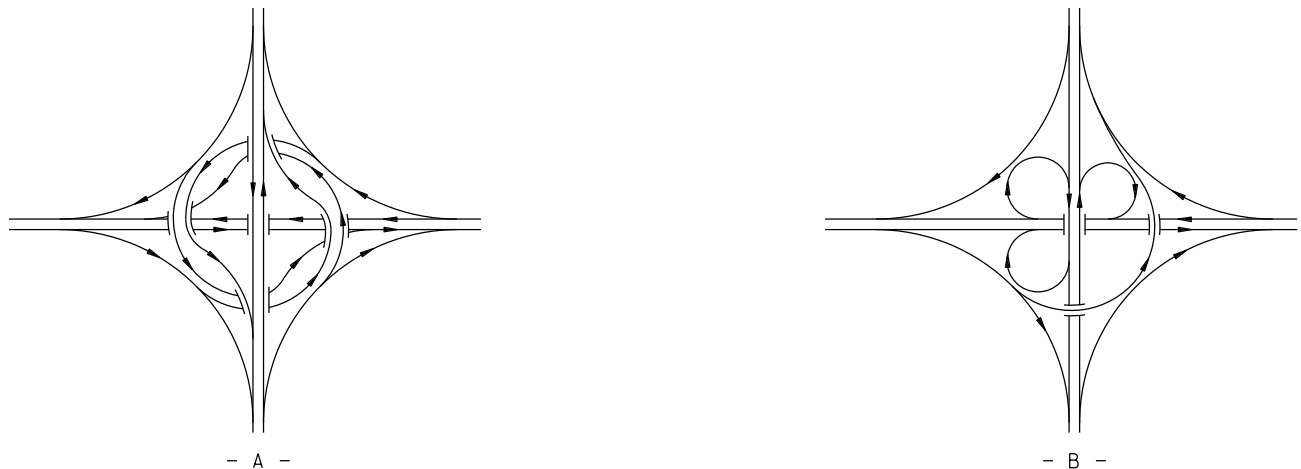
**SEMI-DIRECTIONAL INTERCHANGES****Figure 6-1.03K**

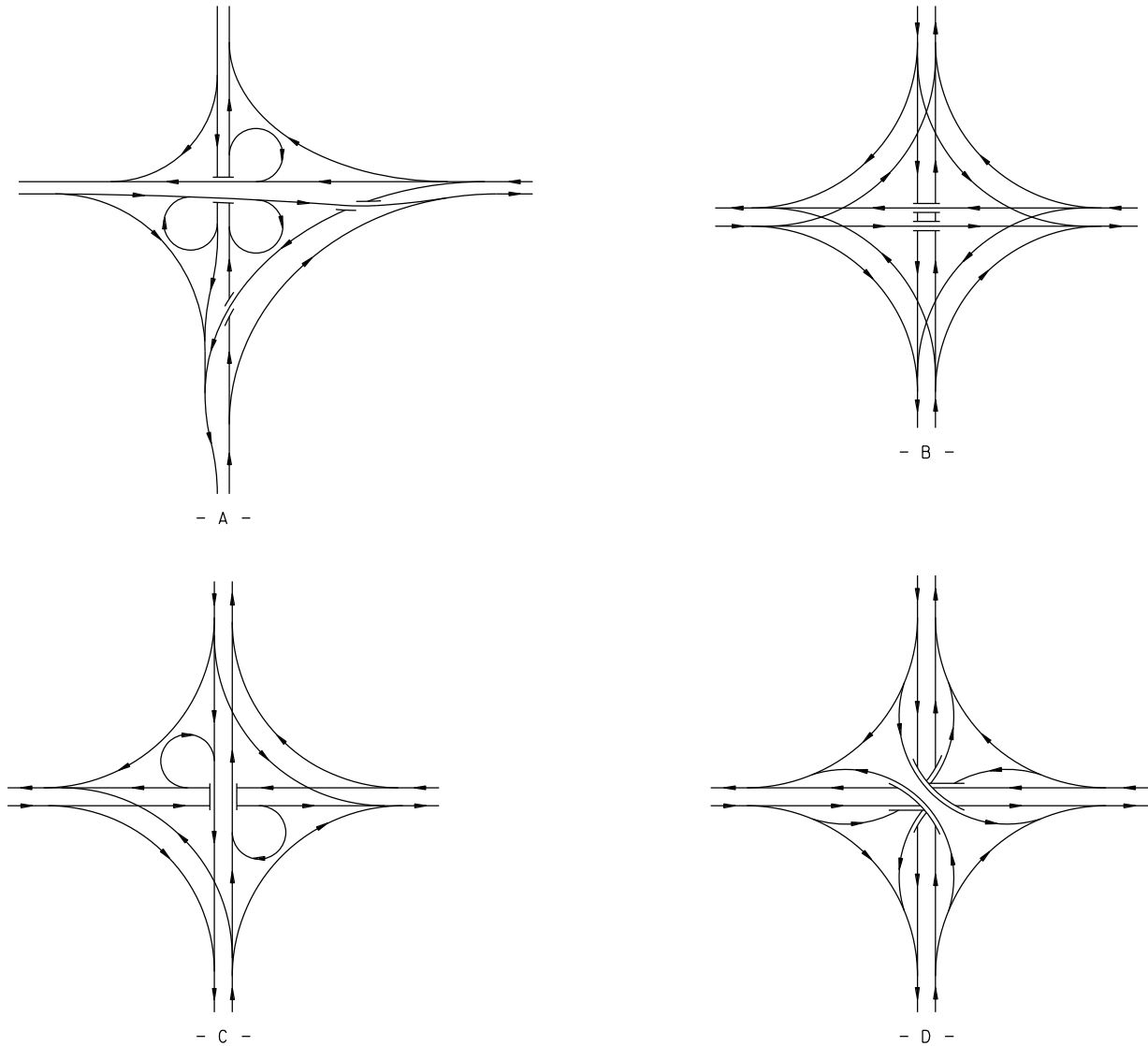

DIRECTIONAL AND FULLY-DIRECTIONAL INTERCHANGES

Figure 6-1.03L

6-1.03.06 Comparing Interchange Forms

Each interchange form has advantages and disadvantages relative to alternative forms. There is no one clearly superior form: SPDIs are better than TDIs in handling left turns from the off ramp, but TDIs are better in handling the minor road through movements. A 4-quad. Parclo A provides higher capacity than any other service interchange form, but it uses more right of way than a TDI or SPDI. There is also a directly proportional relationship between the value provided and the cost incurred; directional interchanges provide very high capacity but are very expensive.

Tables 6-1.03A and B highlight the tradeoffs designers have to make in selecting one form over another. The decision of which form to use should be based on the specific traffic conditions and physical characteristics of the particular location. Refer to Section 6-1.04 for more details.

Table 6-1.03A
COMPARING SYSTEM INTERCHANGE FORMS

Interchange Form	Cost	ROW	Capacity
Full Cloverleaf w/CD	High	Higher	High
Directional/Semi-directional	Higher	High	Higher
Fully Directional	Highest	Highest	Highest

Table 6-1.03B
COMPARING SERVICE INTERCHANGE FORMS

Interchange Form	Construction Cost	ROW	Capacity	Number of Intersections on Minor Road	Signalized Delay on Minor Road	Traffic Progression On Minor Road	Pedestrian Crossing of Minor Road
Conventional Diamond	Low	Medium/Low	Low	Two	High	Worst	Easy
Compressed Diamond	Low	Low	Medium	Two	Medium	Medium	Easy
TDI	Low	Low	Medium	Two	Medium/Low	Good	Easy
SPDI	Highest ¹	Lowest	Medium	One	Medium	Best	Difficult
4-quad. Parclo A	Medium	Medium/High	Highest	Two	Low	Medium	Easy
4-quad. Parclo B	Medium	Medium/High	Medium/High	One	Lowest	Best	Difficult
Parclo AB/ Folded Diamond	Medium	Medium ²	Medium/High ³	Two	Low	Medium	Easy

¹ Because of the bridges and retaining walls in SPDI, reconstruction/modification costs (ex. for widening) are also high.

² ROW is needed in two quadrants only.

³ Weaving may be a problem. Add a CD road, or orient loops so that the weave occurs on the minor road and the turning movements cause the least possible disruption to the mainline (see Figure 6-1.03E, parts A and B).

6-1.04 Concept Development

6-1.04.01 General

Planning and designing an interchange is complex. In rural areas, the interchange can often be studied as a closed system; in urban areas it is usually necessary to analyze the interchange as part of the entire highway system. On freeways where interchanges are most common, the operational efficiency of the interchange tends to govern the entire freeway and therefore represents the greatest hindrance to the efficient flow of traffic, which is the functional purpose of the freeway. Once the design year traffic volumes are estimated, the process can be summarized as follows:

1. Determine warrants for either a grade separation or an interchange.
2. Propose several alternatives.
3. Evaluate each alternative in terms of relative cost, safety, capacity, operation, and integration into the existing highway system.
4. Select the alternate which strikes the most reasonable balance between costs and benefits.
5. Incorporate the detailed design elements to ensure that they adhere to the appropriate standards and that the interchange will realize its anticipated benefits.
6. Review the interchange criteria adopted by the Metropolitan Council in the Twin Cities area; Metropolitan Planning Organizations and Regional Development Commissions in the greater Minnesota area; and the Federal Highway Administration interchange criteria.

6-1.04.02 Capacity

The capacity of a freeway is directly or indirectly dependent upon the capacity of the following individual elements:

1. Basic freeway section where interchanges are not present.
2. Freeway/ramp junctions or terminals.
3. Weaving areas.
4. Ramp proper.
5. Ramp/minor road intersection.

The operational goal of the interchange is to provide sufficient capacity and to avoid gridlock, which can affect the freeway. The capacity of the interchange should be equal to or at least comparable with the operational characteristics of the basic freeway section. To maintain a stable freeway flow, many of the on-ramps in the metropolitan areas may be metered. The main purpose for ramp metering is to avoid operational breakdown at the ramp-freeway junction, and thus to maintain stability of the traffic flow on the mainline. Numerous computer software packages including the Highway Capacity Software (HCS), and simulation packages such as CORSIM, provide methods for estimating the capacity and the level of service for each freeway element. They also describe the relationship between the elements within the interchange.

6-1.04.03 Selection of Interchange Type

Once the warrants, capacity needs and level of service have been established, a specific type of interchange can be selected. Section 6-1.03 provides a comparison between different interchange forms.

One key element in the selection will depend upon whether the interchange will be a “system” or a “service” interchange (see definitions in Section 6-1.01).

Another key element will be the location: urban or rural. In general, interchanges in rural areas can be selected strictly on the basis of service demand and analyzed as a separate unit. In urban areas, specific site conditions may severely limit the feasibility of meeting the service demands as desired, and the selection will likely be significantly impacted by the operational characteristics of the intersecting road and other nearby interchanges.

Designers have to make another important decision: cross the minor road over or under the major road. Chapter 10 of AASHTO's A policy on Geometric Design of Highways and Streets provides a detailed discussion of this issue.

All interchanges should provide for all movements unless this is impractical. Even if the anticipated turning volume is low, the omission of a movement will cause extreme confusion for those drivers who are looking for the connection. An omission places the designer in the position of having to try to predict if future development will significantly increase the demand for the maneuver. Although traffic projections are a part of all highway design elements, the possible negative consequences of omitting a turning maneuver at an interchange are such that the designer should usually ensure that all maneuvers are provided.

Finally, designers should keep the design as simple as possible to facilitate driver comprehension and signing. When conditions dictate a design that does not conform to driver expectancy (left-hand exit, for example), designers should work with Traffic Engineers to provide the necessary advance signing.

Designers can use the following factors to select the appropriate interchange form.

1. System vs. service interchange.
2. Urban vs. rural area.
3. Number of legs.
4. Route continuity, if practical.
5. Uniformity of exit and entrance patterns, if practical.
6. Traffic conditions: exiting/entering volume to/from the mainline, through and turning volumes on the minor road, acceptable amount of delay/LOS for each movement, and need for/type of traffic control on minor road (uninterrupted flow, signal or stop sign).
7. Operational characteristics: single or double exits/entrances, weaving and signing.
8. Lane balance and lane continuity.
9. Road user impacts: travel distance and time, safety, convenience and comfort.
10. Number of pedestrians crossing the minor road.
11. Presence of an attached frontage road.

12. Importance of minor road signal coordination.
13. Right of way impacts and availability.
14. Environmental impacts.
15. Cost of construction.
16. Cost of maintenance.
17. Feasibility of stage construction.
18. Maintenance of traffic for reconstructed interchanges.

It may be difficult to compare the costs and benefits of different interchange forms. Given the typically large financial investments and the long-range impacts of the final selection, it may be warranted to conduct an in-depth cost effective study to aid in the final decision. Section 2-4.03 offers guidance on how this may be done.

6-1.04.04 Distance Between Interchanges

In rural areas, the spacing between interchanges commonly used is 5 to 10 miles. The minimum desirable interchange spacing in rural areas is 2 miles.

In urban areas, the minimum desirable interchange spacing is 1 mile. Where closer spacing is desired or required, the use of collector distributor roads is strongly recommended.

6-1.04.05 Distance Between Successive Ramp Terminals

A reasonable distance between successive ramp terminals is required to provide sufficient maneuvering length and adequate space for signing.

The spacing depends on the classification of the interchanges involved, the function of the ramp pairs (different combinations of entrances and exits), and weaving potential, when applicable. Figure and Table 6-1.04A show the desirable, adequate and absolute minimum values for spacing of ramp terminals, as published in ITE's 1999 Traffic Engineering Handbook.

When the distance between successive noses is less than 1,500 ft, auxiliary lanes should be considered to connect the noses. See Section 6-1.05 for discussion of auxiliary lanes.

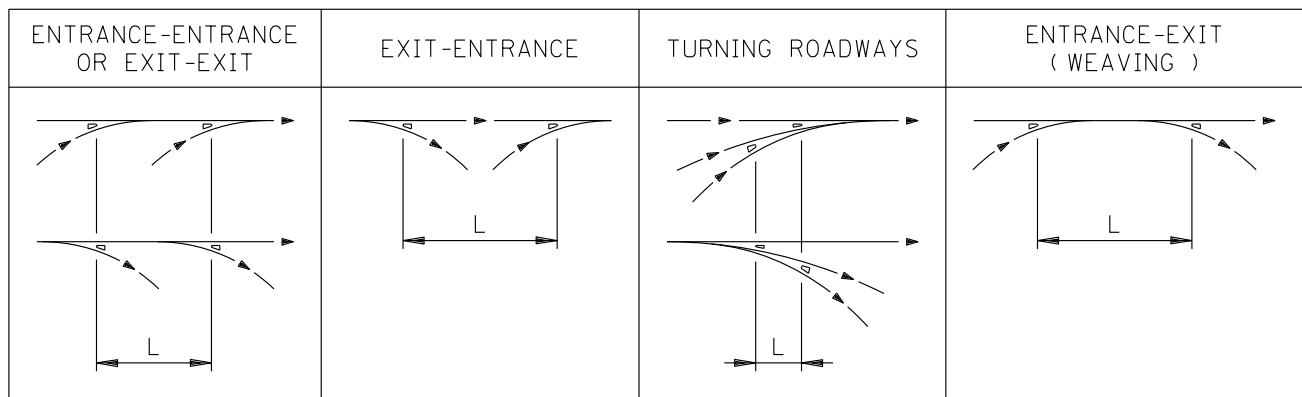

DISTANCE BETWEEN SUCCESSIVE RAMP TERMINALS
Figure 6-1.04A

Table 6-1.04A
Distance Between Successive Ramp Terminals (ft)*

	Entrance – Entrance OR Exit - Exit		Exit – Entrance		Turning Roadways		Entrance - Exit (Weaving)			
	Full Freeway	C-D Road	Full Freeway	C-D Road	System Interchange	Service Interchange	System to Service		Service to Service	
							Full Freeway	C-D Road	Full Freeway	C-D Road
Desirable	1500	1200	750	600	1200	1000	3000	2000	2000	1500
Adequate	1200	1000	600	500	1000	800	2500	1800	1800	1200
Absolute Minimum	1000	800	500	400	800	600	2000	1500	1500	1000

* L in Figure 6-1.04A

C-D = Collector Distributor Road, see section 6-5.0 for discussion.

6-1.04.06 Crash Potential

Safety must be considered in the selection and design of any highway feature, including interchanges. An improperly designed interchange may partially negate the safety benefits of physically separating the through traffic movement. One of the best methods of assessing the safety of a proposed interchange is to review the actual crash data related to interchanges of similar design that have been in operation for several years. Contact your District Traffic Engineer and the Office of Traffic Engineering for such data.

6-1.05 Number of Lanes Through an Interchange

6-1.05.01 General

Certain principles on carrying lanes through an interchange must be adhered to when designing the interchange to accommodate driver expectancy and eliminate operational and safety problems. Designers should be aware that incorporating these principles may cause the elimination of some lane reductions that would be justified on the basis of capacity alone.

6-1.05.02 Basic Number of Lanes

The basic number of lanes is defined as the minimum number of lanes maintained over a significant length of a route based on the capacity needs of that section. That number is predicated on the general volume level of traffic over a substantial length of the facility. The volume is the Design Hourly Volume (DHV) representative of A.M. or P.M. weekday peak. Localized variations in traffic volume are ignored. Thus, volumes on short sections below the general level would theoretically have reserve capacity, while volumes on short sections somewhat above the general level would be compensated for by the addition of auxiliary lanes introduced within these sections.

An increase in the basic number of lanes is warranted where traffic builds up sufficiently to justify an extra lane and where such buildup raises the volume level over a substantial length of the facility. The basic number of lanes may be decreased where traffic is reduced sufficiently to drop a basic lane, provided there is a general lowering of the volume level on the freeway route as a whole.

The basic number of lanes should be carried through an interchange even if the traffic volume theoretically warrants dropping a lane at the exit. Dropping a lane at an exit can unduly complicate its traffic operation and thus should be done downstream from the interchange. Following the same principle, the basic number of lanes should be carried through between closely spaced interchanges.

6-1.05.03 Lane Balance

To realize efficient traffic operation through and beyond an interchange, there should be balance in the number of traffic lanes on the freeway and ramps. DHV and capacity analysis determine the basic number of lanes

on the highway and the minimum number of lanes on the ramps. After the basic number of lanes is determined, the balance in the number of lanes should be checked on the basis of the following principles:

1. At entrances, the number of lanes beyond the merging of two traffic streams should not be less than the sum of all traffic lanes on the merging roadways minus one.
2. At exits, the number of approach lanes on the highway must be equal to the number of lanes on the highway beyond the exit plus the number of lanes on the exit, less one. Two exceptions to this principle are acceptable: at cloverleaf loop ramp exits which follow a loop ramp entrance, and at exits between closely spaced interchanges and a continuous auxiliary lane between the terminals is being used. In these two cases, the auxiliary lane may be dropped in a single-lane exit leaving the number of approach lanes on the highway equal to the number of through lanes beyond the exit plus the lane on the exit.
3. The traveled way of the highway should not be reduced by more than one traffic lane at a time.

Figure 6-1.05A illustrates the coordination of the concepts of lane balance and basic number of lanes. Refer to AASHTO for more details.

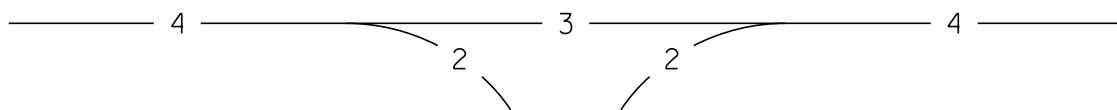

LANE BALANCE
 BUT NO COMPLIANCE WITH BASIC NUMBER OF LANES
 - A -

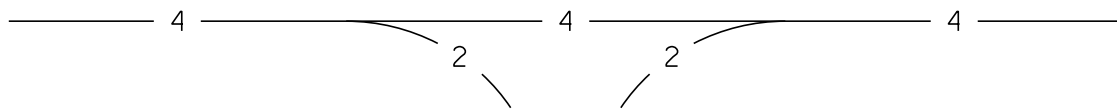

NO LANE BALANCE
 BUT COMPLIANCE WITH BASIC NUMBER OF LANES
 - B -

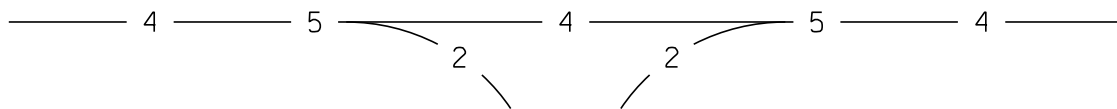

COMPLIANCE WITH BOTH LANE BALANCE
 AND BASIC NUMBER OF LANES
 - C -

COORDINATION OF LANE BALANCE AND BASIC NUMBER OF LANES
Figure 6-1.05A

6-1.05.04 Auxiliary Lanes

At interchanges, an auxiliary lane is a full width travel lane that is developed to facilitate traffic operation. Auxiliary lanes are most often used to:

1. Comply with the principle of lane balance.
2. Comply with capacity requirements in the case of adverse grades.
3. Accommodate speed changes.
4. Accommodate weaving.
5. Accommodate traffic pattern variations at interchanges.
6. Accommodate maneuvering of entering and exiting traffic.
7. Simplify traffic operations by reducing the number of lane changes.

Continuous auxiliary lanes should be constructed between the entrance and exit terminals of interchanges where the distance between the end of the entrance terminal taper and the beginning of the exit terminal taper is short. AASHTO recommends that an auxiliary lane be used to connect the acceleration and deceleration lanes when the distance between successive noses is less than 1,500 ft.

An auxiliary lane may be introduced as a single exclusive lane, or in conjunction with a 2-lane entrance. The termination of an auxiliary lane may be accomplished by several methods. Figure 6-1.05B provides the basic schematics of designs for adding and dropping auxiliary lanes within and beyond interchanges. The design should be based on the traffic volumes for the exiting, entering and through movements. Design details for exits and entrances are provided in Section 6-2.0.

6-1.05.05 Escape Lanes

AASHTO uses the term Recovery Lane to describe what MnDOT refers to as an Escape lane. An escape lane is a short auxiliary lane located beyond an exit ramp or a major fork divergence to provide refuge for vehicles that are not able to exit/merge.

Escape lanes should only be provided where needed. Conditions that warrant building an escape lane include:

1. Closely spaced ramps where the distance between the theoretical noses is less than 1/2 mile (3/4 mile between the physical noses). For example at interchanges with two consecutive loops in the direction of travel.
2. Where traffic volume/capacity and weaving conditions warrant their use.

The design details of escape lanes are shown in Standard Plan Sheet 5-297.105. Where an escape lane is not warranted, the wide gore area shown in the same Standard Plan sheet may be used. If an escape lane is warranted but due to site restrictions cannot be fully developed (for example at some cloverleaves and folded diamond/Parclo AB interchanges) a modified escape lane may be used as shown in Figure 6-2.03C or in the alternate design in Figure 6-2.03D.

6-1.06 Right of Way and Access Control

Proper control of access must be maintained within and near an interchange in order to ensure its integrity. This is accomplished by acquiring sufficient right of way, and restricting the proximity of public and private access to the ramp/minor road at-grade intersection. Section 2-3.06 discusses the value of access control and provides several figures which illustrate the required right of way and access control provisions at interchanges. Contact MnDOT's Access Management Section for additional guidance.

6-1.06.01 Expressway On-Ramps

Service interchanges between a freeway and an expressway pose a particular need for sufficient access control downstream from the ramp/expressway junction. The envelope of influence of an on-ramp affects the traffic for some distance from the ramp nose. Therefore, any right-in/right-out entrances or roadway connections should not be constructed closer than 1,800 ft downstream from the nose, see Figure 2-3.06B.

Any roadway connections which include a median cross-over should not be closer than 2,500 ft downstream from the nose of an on-ramp.

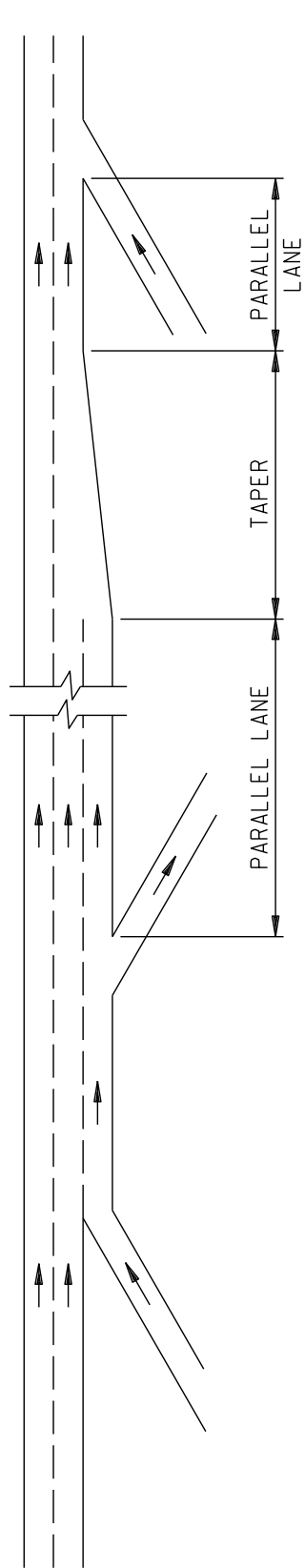

AUXILIARY LANE ADDED AND DROPPED WITHIN AN INTERCHANGE

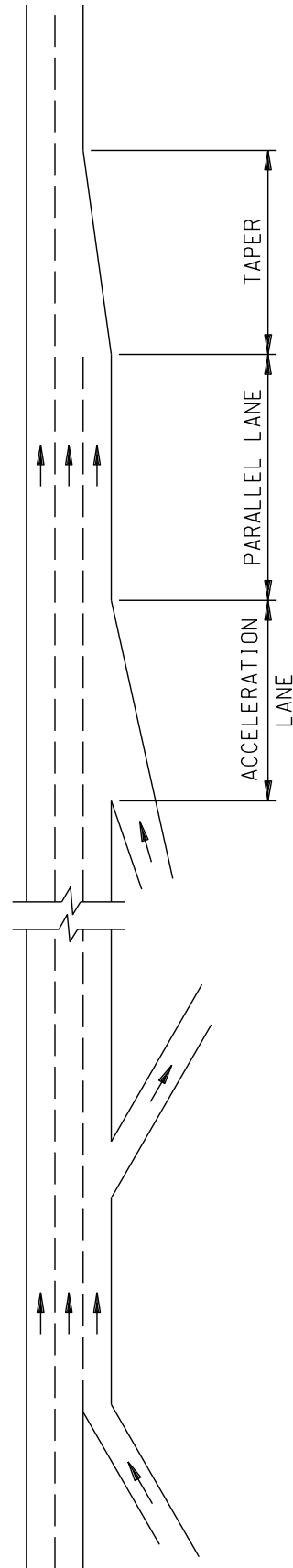

AUXILIARY LANE ADDED AND DROPPED BEYOND AN INTERCHANGE

AUXILIARY LANES AT INTERCHANGES
Figure 6-1.05B

6-2.0 RAMP-FREEWAY AND RAMP-STREET JUNCTIONS (TERMINALS)**6-2.01 General**

The design of ramp junctions for exits from and entrances onto freeways and ramp-street junctions will have a significant impact upon the safety, operation and capacity of the interchange.

The ramp-freeway junctions where merging and diverging movements take place should operate at freeway speeds without disruption of the freeway traffic stream. The ramp-street junctions should be designed to accommodate large trucks and double left turns where appropriate. In metro areas where it is determined necessary to provide metered ramps and HOV (High Occupancy Vehicle) bypass lanes, the entrance ramps should be designed with proper approaches. The designer should refer to the Highway Capacity Manual to compute the capacity and level of service for the ramp junctions.

6-2.02 Sight Distance

Drivers should be given sufficient sight distance at ramp-freeway junctions, and at exit ramp-cross street junctions. Sight distance formulae and design values are presented in section 2-5.0.

6-2.03 Exit Ramp Design**6-2.03.01 Deceleration Lanes (Tangent Mainline)**

If the exit ramp is designed to properly provide for deceleration, driver comfort and traffic operation will be maximized and the impact upon the highway mainline will be minimized. The key elements are proper driver notification and allowing all deceleration to occur within the deceleration lane away from the mainline. The length and type of lane will depend upon the design speed of the mainline and the reduced speed of the first curve on the ramp. In addition, it is preferable, if possible, that all deceleration lanes be on a tangent mainline.

Deceleration lanes may be of the taper design or parallel design. MnDOT's standard practice is to provide, where possible, the taper deceleration design shown in Figure 6-2.03A and in the Standard Plans Manual. The parallel design (shown in AASHTO) has the disadvantage of requiring the driver to perform a reverse curve maneuver. Furthermore, that design may induce some through-drivers to believe that the additional lane is a main line lane rather than an exit lane.

When using MnDOT's taper design, the first curve on the exit ramp should not exceed 6 deg. The preferred curvature of the first curve is 4 degrees or flatter if site conditions allow. It may not always be possible to meet this criterion where site conditions are restricted. This is particularly true for Parclo AB (folded diamond interchanges), where a loop serves as the exit beyond the structure. In cases where the standard taper design does not provide sufficient length for deceleration, a variation of the taper design type will be required. This variation modifies the taper design by incorporating additional parallel deceleration length as shown in Figure 6-2.03B. When this design is called for, Table 6-2.03A gives the minimum total length (parallel lane and deceleration lane) for deceleration at exits on flat grades (2 percent or less). Where grades are in excess of 2 percent, the deceleration length should be adjusted in accordance with Table 6-2.03B. The length is measured from the point at which the deceleration lane reaches a 12 ft width to the beginning of the first curve on the ramp corresponding to the chosen design speed. An exit taper (into the deceleration lane) of 1:15 should be provided.

MnDOT's taper design provides approximately 375 ft for deceleration. If the deceleration length given in Tables 6-2.03A and 6-2.03B is less than or equal to 375 ft, MnDOT's taper design will be sufficient and should be used. Table values greater than 375 ft indicate the need for additional parallel deceleration length (the parallel lane length being equal to the table value minus 375). However, to avoid abrupt reverse curve maneuvers, it is recommended that a minimum parallel length of 100 ft be used. Therefore when the deceleration length given in Tables 6-2.03A or 6-2.03B is between 375 and 475 ft, the recommended design is a taper design with an additional 100 ft parallel length.

The deceleration and acceleration lanes on two consecutive loops (cloverleaf or ParcloAB/Folded diamond interchange) are interconnected with auxiliary lanes. The loop alignment should be designed using 3-centered curves (see Figure 6-2.03C) such that flatter curves at the beginning and end of loops take the place of tapers.

Where the weaving volume (sum of traffic on two consecutive loops, the first an entrance, the second an exit) approaches 1000 vph, or where the length of the parallel weaving area is shorter than required for comfortable deceleration (thereby necessitating some deceleration on the adjacent mainline lane), the design shown in Figure 6-2.03D may be considered if a C-D road is not possible. This design includes a parallel lane developed in advance of the entrance terminal and carried beyond the exit terminal, allowing all acceleration, deceleration and weaving maneuvers to occur off of the mainline lanes. The points of introduction and termination of the parallel lane should be based on the anticipated needs for acceleration, deceleration and traffic operations combined with considerations for weaving. If possible, the entrance ramp directly downstream of this type of weaving area should be aligned so that sufficient space is created to allow the prescribed length of parallel lane. If constraints do not permit such an optimal lane length, the designer may choose either to compromise the parallel lane length to fit the constraints or to continue

the lane at full width though the subsequent entrance and terminate it at a logical location downstream. Due to the negative operational effects the cloverleaf loop situation tends to have on high-traffic facilities, the additional expense incurred to provide the prescribed design parameters is likely to be justified on the basis of bottleneck avoidance.

Superelevation must be properly developed in deceleration lanes. Refer to Section 3-2.0 for details.

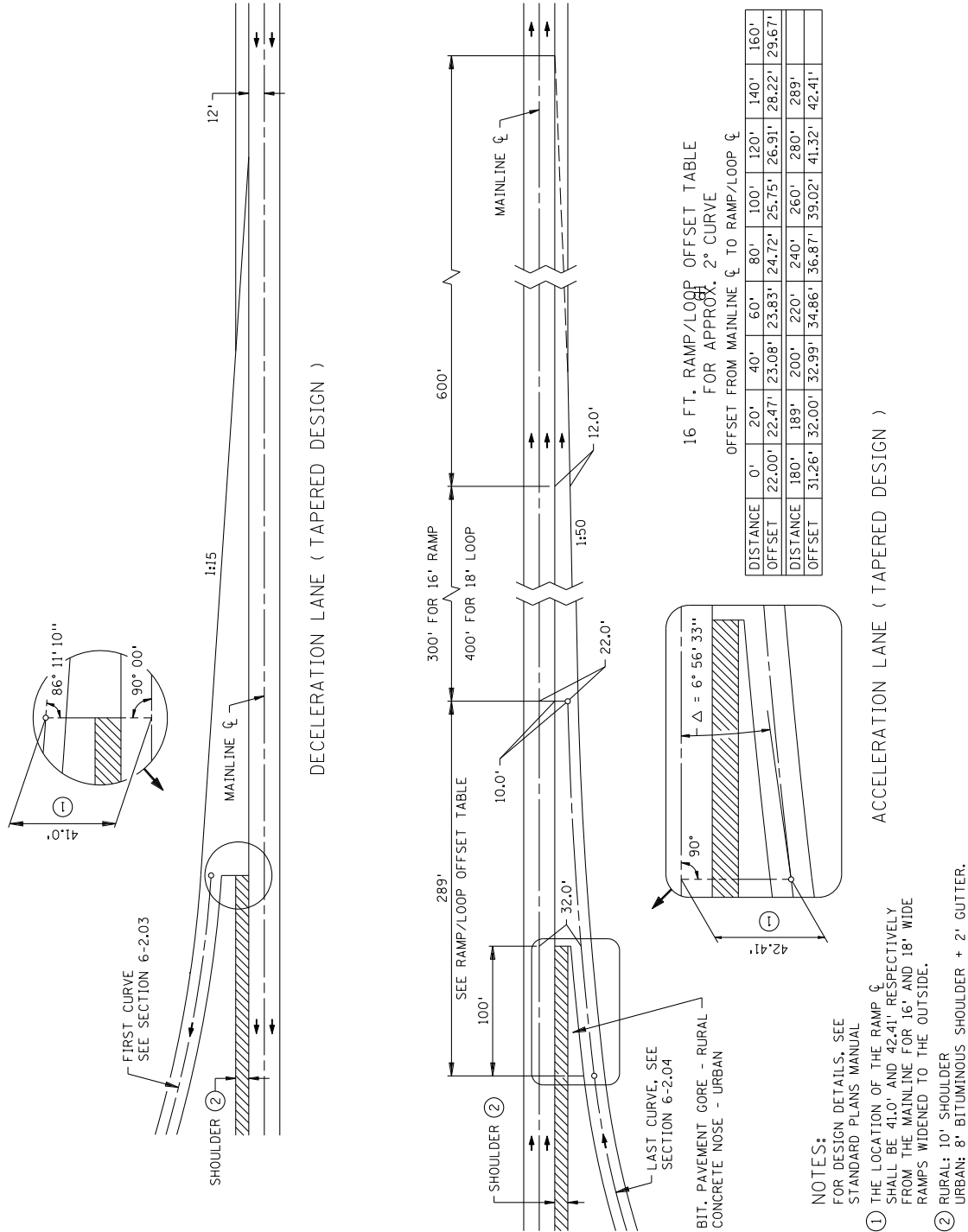

**ACCELERATION AND DECELERATION LANES, MAINLINE TANGENT SECTION
 TAPERED DESIGN
 Figure 6-2.03A**

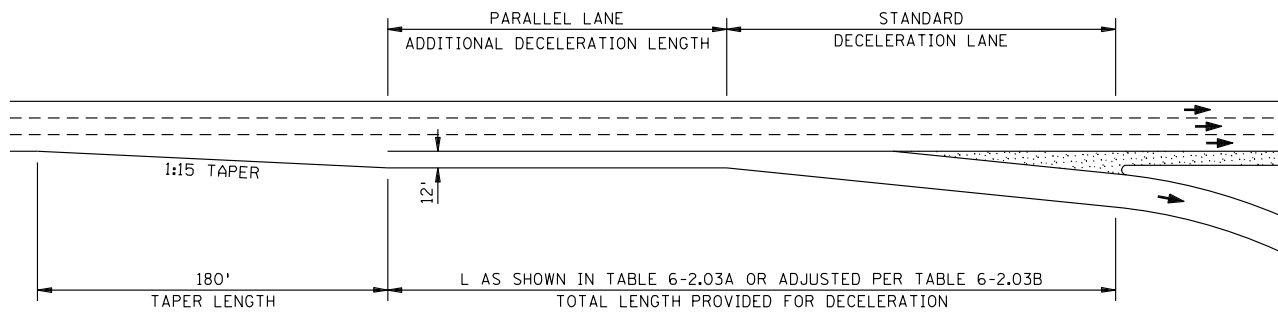

**DECELERATION LANE, MAINLINE TANGENT SECTION,
TAPER DESIGN WITH ADDITIONAL PARALLEL DECELERATION LENGTH
Figure 6-2.03B**

**Table 6-2.03A
TOTAL LENGTHS FOR DECELERATION FOR EXITS ON FLAT GRADES
(2% OR LESS)* - MINIMUM VALUES**

HIGHWAY DESIGN SPEED, MPH	AVERAGE RUNNING SPEED, MPH	L = DECELERATION LENGTH (FT)								
		FOR DESIGN SPEED OF FIRST EXIT CURVE (MPH)								
		STOP CONDITION	15	20	25	30	35	40	45	50
		FOR AVERAGE RUNNING SPEED ON EXIT CURVE (MPH)								
		0	14	18	22	26	30	36	40	44
30	28	235	200	170	140	-	-	-	-	-
35	32	280	250	210	185	150	-	-	-	-
40	36	320	295	265	235	185	155	-	-	-
45	40	385	350	325	295	250	220	-	-	-
50	44	435	405	385	355	315	285	225	175	-
55	48	480	455	440	410	380	350	285	235	-
60	52	530	500	480	460	430	405	350	300	240
65	55	570	540	520	500	470	440	390	340	280
70	58	615	590	570	550	520	490	440	390	340
75	61	660	635	620	600	575	535	490	440	390

*For steeper grades, use Table 6-2.03B to adjust the lengths shown in this Table.

**Table 6-2.03B
ADJUSTMENT FACTORS FOR DECELERATION LANES ON GRADE (> 2%)**

Design Speed of Highway (mph)	Deceleration Lanes on Grade Adjustment Factors	
	All Speeds	3 to 4 percent upgrade 0.9
All Speeds	5 to 6 percent upgrade 0.8	5 to 6 percent downgrade 1.35

Multiply the factor from this Table by the length in Table 6-2.03A to get the length of deceleration lane on grade.

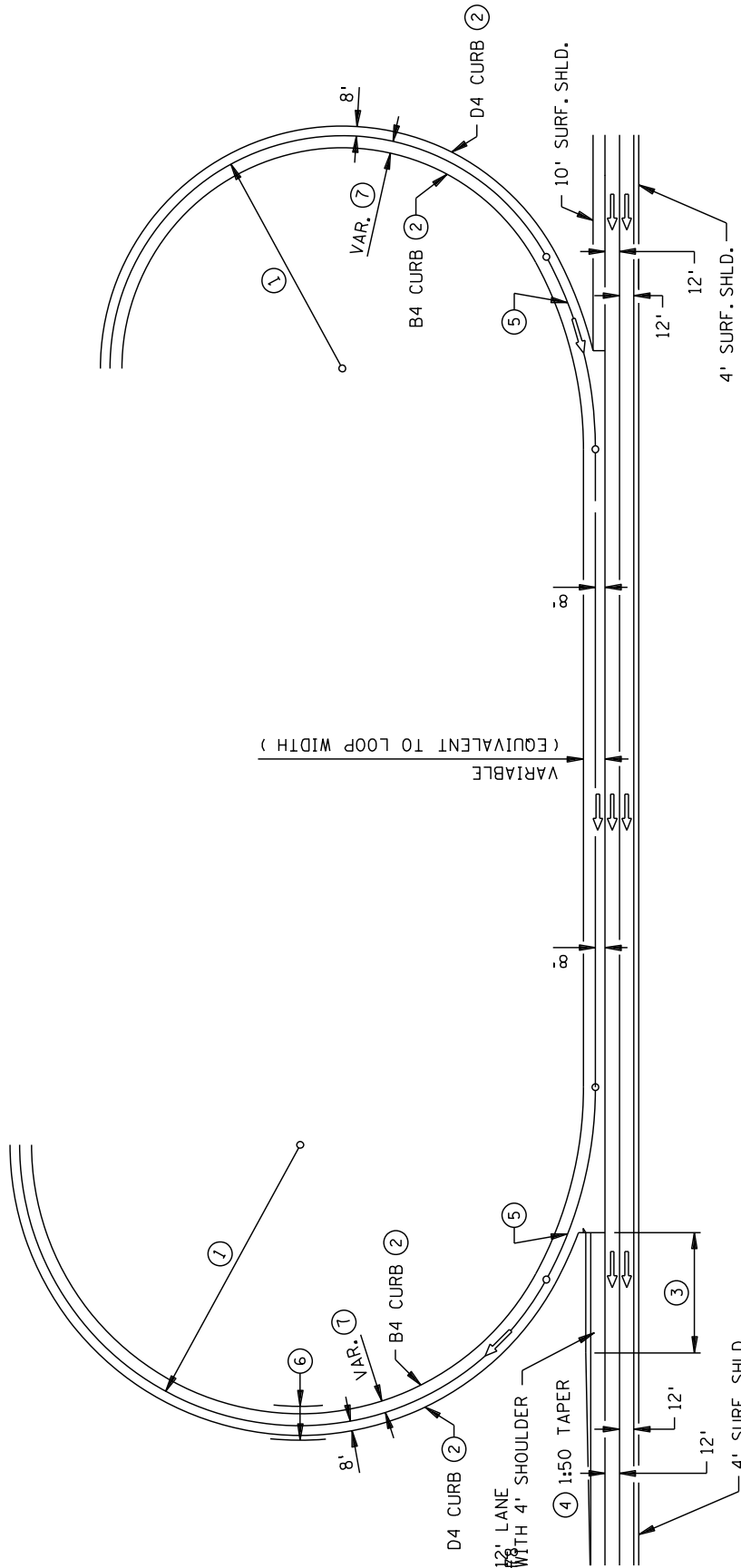

NOTES

- ① SEE SECTION 6-3.04 FOR VALUES OF LOOP RADII.
- ② APPLIES TO URBAN CROSS SECTION ONLY
- ③ 100 FT. PREFERRED MINIMUM TANGENT DISTANCE. MAY BE CUT BACK TO 50 FT. IF SPACE FOR 1:50 TAPER IS LIMITED.
- ④ VARIABLE. (1:50 DESIREABLE) DEPENDING ON THE DISTANCE BETWEEN THE LOOP AND THE RAMP. TAPER SHOULD RUN OUT APPROXIMATELY 65 FT. BEFORE THE SUBSEQUENT RAMP NOSE.
- ⑤ COMPOUND TRANSITION RADIUS, IF DESIRED. SEE SECTION 6-3.04 FOR DESIGN VALUES FOR RADIUS AND LENGTH.
- ⑥ FOR RURAL DESIGN USE RURAL RAMP SECTION WITH 4 FT. AND 7 FT. SHOULDERS.
- ⑦ SEE 6-3.04 FOR WIDTH CRITERIA.

CLOVERLEAF/TWO CONSECUTIVE LOOPS DESIGN

Figure 6-2.03C

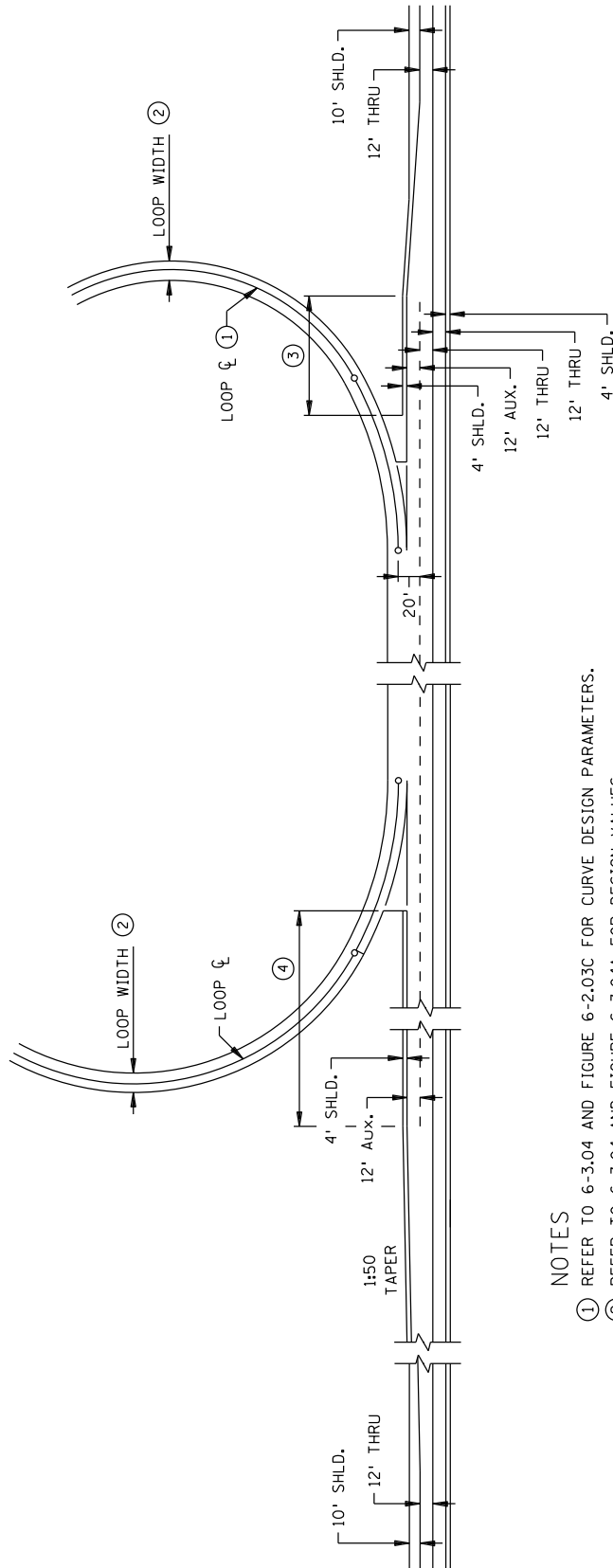

NOTES

- ① REFER TO 6-3.04 AND FIGURE 6-2.03C FOR CURVE DESIGN PARAMETERS.
- ② REFER TO 6-3.04 AND FIGURE 6-3.04A FOR DESIGN VALUES. RURAL RAMP SECTION WILL HAVE LEFT AND RIGHT SHOULDERS IN ADDITION TO WHAT IS PICTURED.
- ③ AS REQUIRED FOR COMFORTABLE DECELERATION PER TABLE 6-2.03A.
- ④ AS REQUIRED FOR ACCELERATION AND/OR WEAVING PER 6-2.06 AND TABLE 6-2.04B. REFER TO DISCUSSION IN 6-2.04 FOR GUIDANCE IN SITUATIONS WHERE PHYSICAL CONSTRAINTS DO NOT PERMIT CONSTRUCTION OF AN OPTIONAL LANE WIDTH.

**ALTERNATE DESIGN – ADD AUXILIARY LANE
FOR INTERCHANGES WITH 2 CONSECUTIVE LOOPS
IN DIRECTION OF TRAVEL AND HIGH WEAVING VOLUME**
Figure 6-2.03D

6-2.03.02 Deceleration Lanes (Left-Curving Mainline)

Development of deceleration lanes on left-curving mainline poses a significant problem in driver adjustment when the subsequent ramp curve is right-curving. A special design deceleration lane has been developed to acclimate the driver to a subsequent turn to the right. The deceleration lane uses a length of 375 ft plus an appropriate taper length in which to exit from a mainline roadway. To ease design and operational problems, the part of the deceleration lane adjacent to the mainline should preferably be either all on a tangent mainline or all on a curved mainline; i.e., the deceleration lane should be placed either upstream or downstream from the P.C. of the mainline. Otherwise, the deceleration lane may appear to be an extension of the mainline tangent, possibly confusing motorists. However, if an acceleration or deceleration lane has to include the P.C., care should be taken to develop a special design.

Figure 6-2.03E illustrates the general development of both 16 ft and 18 ft ramps for a left-curving mainline. The preferred development of 18 ft width on ramps (loop ramps), both urban and rural, is to widen the ramp 2 ft to the outside (driver's right) and lengthen the tapers accordingly. For ease of computation, it has been deemed appropriate to arbitrarily set "F" at 41 ft. Since the width of the roadway portion of the ramp and mainline remain unchanged, the result will be a minor change in the nose width. This change will not be apparent to a driver.

An appropriate procedure must be selected from the computational method shown below when using the 375 ft dimension in computation. For mainline deg of curve, 2 deg and flatter, the "M" distance is held at 375 ft and angle θ is varied from the normal 90 degrees. For mainline deg of curves approaching 2 deg – 15 min and greater, the angle θ is equal to 90 degrees and the "M" is 375 ft or less. An added segment of tangent length "N" is used in advance of the right turning ramp curve, "N" = 375 ft - "M".

Table 6-2.03C gives the values of the angle θ , M, F, and angle Δ for either 16ft or 18 ft ramps. Data for any curves not listed can be computed as follows:

Computations for Δ , M and θ (see Figure 6-2.03E):

$$F = 41 \text{ ft and } F1 = 16 \text{ ft}$$

$$A = R + F$$

$$B = R + F1$$

Where R = Equivalent Radius of Centerline Degree of Curve

For θ greater than 90 deg and M = 375 ft:

$$\Delta = \text{Arccosine} \left(\frac{A^2 + B^2 - 375^2}{2xAxB} \right)$$

$$\theta = \text{Arccosine} \left(\frac{B^2 + 375^2 - A^2}{2x375xB} \right)$$

$$M = 375.0 \text{ ft}$$

For θ equal to 90 deg and M less than 375 ft :

$$M = \sqrt{A^2 - B^2}$$

$$\Delta = \text{Arc tangent} \left(\frac{M}{B} \right)$$

$$\theta = 90 \text{ deg}$$

The deg of curve and Δ at which $\theta = 90$ deg and M = 375 ft are:

$$D_c = 2.0580 \text{ deg}$$

$$\Delta = 7.62815 \text{ deg}$$

Figure 6-2.03F illustrates the proper design when both mainline and ramp curve to the left.

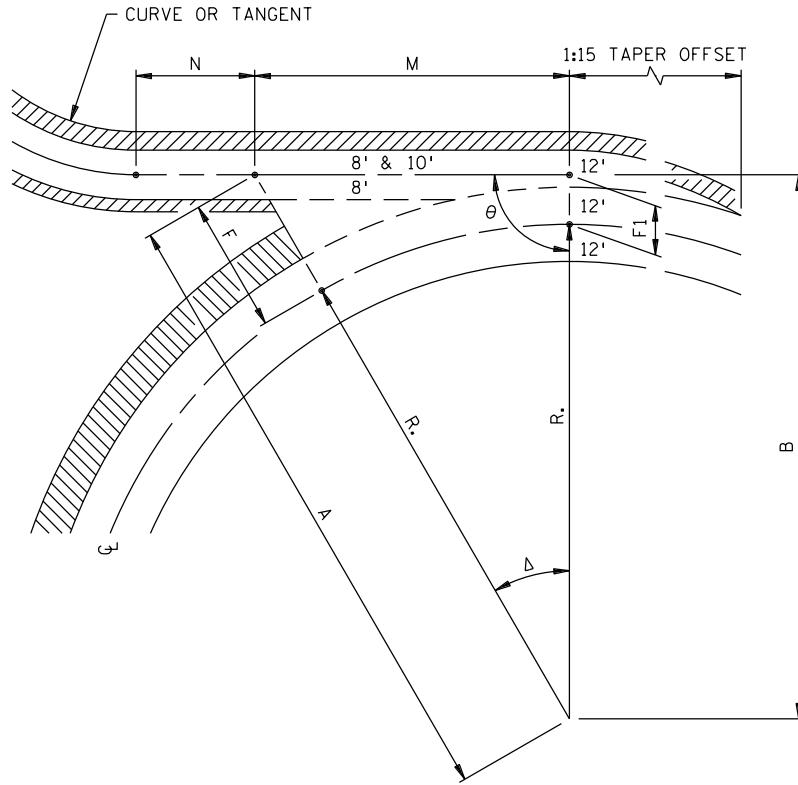

EXIT RAMP ON LEFT CURVING MAINLINE
Figure 6-2.03E

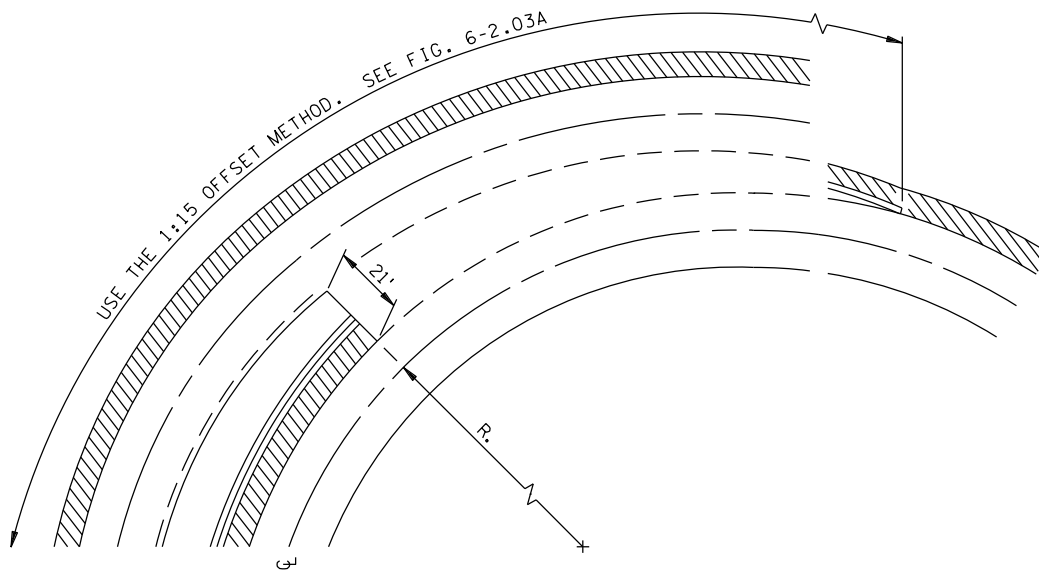

LEFT CURVING EXIT RAMP OFF LEFT CURVING MAINLINE
Figure 6-2.03F

Table 6-2.03C
DATA FOR EXIT RAMP OFF LEFT-CURVING MAINLINE

16' Ramp and Ramp Widened to 18'				
Degree of Curve (Degrees)	M (Feet)	F (Feet)	θ (Degree)	Δ (Degrees)
0.250	375.000	41.00	93.3553	0.9343
0.500			92.8889	1.8663
0.750			92.4234	2.7961
1.000			91.9586	3.7238
1.250			91.4947	4.6495
1.500			91.0315	5.5732
1.750			90.5690	6.4949
2.000			90.1071	7.4148
2.058			90.0000	7.6282
2.125			90.0000	7.7496
2.2245	*		*	*
2.250	358.816		90.0000	7.9711
2.375	349.353			8.1863
2.500	340.612			8.3957
2.625	332.505		↑	8.5996
2.750	324.960			8.7985
2.875	317.915			8.9927
3.000	311.317			9.1825
3.125	305.120			9.3681
3.250	299.286			9.5499
3.375	293.782			9.7280
3.500	288.576			9.9026
3.625	283.644		↓	10.0739
3.750	278.961			10.2421
3.875	274.509			10.4074
4.000	270.268			10.5697
4.250	262.358			10.8865
4.500	255.121			11.1934
4.750	248.468			11.4911
5.000	242.324			11.7805
5.250	236.627			12.0620
5.500	231.327			12.3363
5.750	226.379			12.6038
6.000	221.746			12.8649
6.250	217.397			13.1200
6.500	213.304			13.3695
6.750	209.443			13.6137
7.000	205.793			13.8529
7.250	202.335			14.0873
7.500	199.053			14.3171
7.750	195.934			14.5426
8.000	192.963	41.00	90.000	14.7640

* This line gives Degree of Curve value when θ becomes 90° for other ramp width and does not provide values for ramp width where * appears, i.e., 2.058 is degree of curve where θ becomes 90° for 16-foot ramp.

6-2.03.03 Gore Area

The gore area between the divergence of the mainline and the ramp is normally considered to be both the paved triangular area upstream from the gore nose and the graded area which extends a few feet downstream beyond the gore nose. For detailed development of gore areas, see the Standard Plans Manual. The primary difference between the rural and urban designs is the presence of curbs in the urban design. Standard Plate 7108 provides details for designing the concrete curb and exit nose for the urban gore area.

Exit gore areas have experienced a relatively high accident rate in the past. This may be attributable to the following: (1) the decision point at the divergence complicates the driver task and increases the potential for accidents; (2) fixed roadside obstacles or non-traversable roadsides were typically located downstream from the gore nose; and (3) inadequate driver warning or improper geometric design details may have been present. Therefore, the design of the gore area deserves special attention. The following should be considered in design:

1. Signing in advance of the exit and at the divergence should be in accordance with the MN MUTCD. This also applies to the paint markings in the triangular area upstream from the gore nose. Rumble strips may also be considered in this area.
2. If possible, the area beyond the gore nose should be free of signs and luminaire supports. If they must be present, they should be yielding or breakaway or shielded by a crash cushion. On roadways where a physical structure must be located in the gore area, a crash cushion reserve area should be provided as shown in Chapter 10 of this manual.
3. The graded area beyond the gore nose should be as flat as possible. If the elevation difference between the exit ramp or loop and the mainline increases rapidly, this may not be possible. These areas will likely be non-traversable and the gore design should shield these areas from the motorist. Often, the vertical divergence of the ramp and mainline will warrant protection for both roadways beyond the gore.

6-2.04 Entrance Ramp Design

6-2.04.01 Acceleration Lanes

As with deceleration lanes at exit ramps, a properly designed acceleration lane will facilitate driver comfort, traffic operations, and safety. There must be an adequate system for driver warning, and the entering driver should be allowed to comfortably accelerate to the appropriate speed and smoothly merge into the mainline traffic stream.

Entrance ramps offer a greater potential for vehicle conflict than exit ramps. Entering a highway may be the most complicated task a driver encounters, particularly where traffic volumes are high. The driver must simultaneously keep his vehicle in the lane, accelerate the vehicle, look over his shoulder or in the mirrors to select a gap in the mainline traffic stream, and watch for slowed or stopped vehicles ahead in the acceleration lane.

Entrance acceleration lanes may be of the taper or parallel design. The taper design works on the principle of a direct entry at a flat angle, whereas the parallel design provides an added lane (parallel to the mainline lanes) of sufficient length to enable a vehicle to accelerate to near-freeway speed prior to merging. Refer to AASHTO's [policy on Geometric Design of Highways and Streets](#), for guidance on the design of parallel acceleration lanes.

The design of a tapered acceleration lane to a tangent mainline was shown in Figure 6-2.03A and also in the Standard Plans Manual. The design of a tapered acceleration lane that enters on the outside of a curving mainline is shown in Figure 6-2.04A and Table 6-2.04A. It is recommended that the curvature of the last curve on the ramp not exceed 6 deg. The preferred curvature of the last curve is 4 deg or flatter if the site conditions allow.

There are two conditions where the taper design by itself is not adequate. They are explained in the next two paragraphs.

The first condition occurs when entering vehicles are not able to approach mainline speeds within the length provided by the taper design. In this case, an additional acceleration length should be provided. This is accomplished by modifying the taper design to incorporate an additional length beginning at the point where the acceleration lane is 12 feet in width (see Figure 6-2.04B). Thus, the total length available for acceleration begins at the critical velocity point (defined below) and terminates at the beginning of the merging taper. For guidance on the total length needed for acceleration refer to Table 6-2.04B, it provides the minimum length of acceleration lanes for various combinations of design speeds for ramp and loop and the highway mainline at terminals featuring flat longitudinal grades (2 percent or less). Where grades are in excess of 2 percent, the acceleration length should be adjusted in accordance with Table 6-2.04C. The critical velocity point will most often be the end of the last curve on the ramp or loop. In the case of compound curvature approaching the entrance, both curves should be examined using the achieved design speed for each. For some metered ramps, the critical velocity point may be determined to be the

meter location, based on a stop condition at that point. In these cases, an individual judgment should be made as to whether providing acceleration length based on that consideration is justified.

In the second condition, the taper design provides sufficient distance for acceleration but insufficient distance for entering vehicles to find an acceptable gap in the mainline traffic stream because of heavy traffic volumes. In these cases a parallel lane should be provided with a length which will allow a safe merge based on the entering ramp and mainline traffic volumes. An individual traffic analysis will be needed to determine the proper length of the parallel lane.

As with deceleration lanes, the taper acceleration lane design may not apply where an entrance loop/ramp is immediately followed by an exit loop/ramp such as occurs at full cloverleaf or folded diamond interchanges. Where the distance between the ramp terminals is such that the tapered paths of the exiting and entering traffic would overlap or otherwise coincide, a parallel type entrance and auxiliary lane should be applied. See Figure 6-2.03C. It will often be necessary to extend the acceleration lane for the entrance loop beyond the gore for the exit loop, as shown in the figure. Section 6-2.06 on Weaving, and the Highway Capacity Manual, discuss this situation in greater detail.

Where the length between entering and exiting ramps is exceedingly short, such as occurs with two consecutive loops, the design shown previously in Figure 6-2.03D, may be considered. This design includes a parallel lane developed in advance of the entrance terminal and carried beyond the exit terminal, allowing all acceleration, deceleration and weaving maneuvers to occur exclusive of the mainline lanes. The points of introduction and termination of the parallel lane should be based on the anticipated needs for acceleration, deceleration and traffic operations combined with considerations for weaving.

The merging taper rate at the end of all acceleration lanes should be 1:50.

6-2.04.02 Gore Areas

The term "gore area" is also used to apply to the area immediately upstream from the point of convergence between the entrance ramp or loop and the highway mainline. The design of this area is not nearly as critical as the gore area at an exit; however, certain design details are applicable. The Standard Plans Manual provides the gore designs for rural and urban highways, with the basic difference being the provision of curbs in the urban design. Standard Plate 7107 provides the design details for the entrance gore nose. The gore nose at the convergence point is truncated at a 2 ft width. The Standard Plans Manual also provides the necessary information to determine the offset from the mainline to the ramp at the point where the last ramp curve ends.

6-2.05 Multi-Lane Exits and Entrances

Multi-lane exits and entrances may be warranted where traffic volumes exceed the capacity of a single lane ramp. The capacity of a ramp depends on the free flow speed of the ramp. Refer to the Highway Capacity Manual for guidance.

The main use of multi-lane ramps is at directional systems interchanges where there is a benefit in providing the design consistency of multi-lane highways through the interchange. The design of multi lane entrances and exits is the same as the MnDOT design for major highway fork entrances and exits. These designs are discussed in Section 6-6.0.

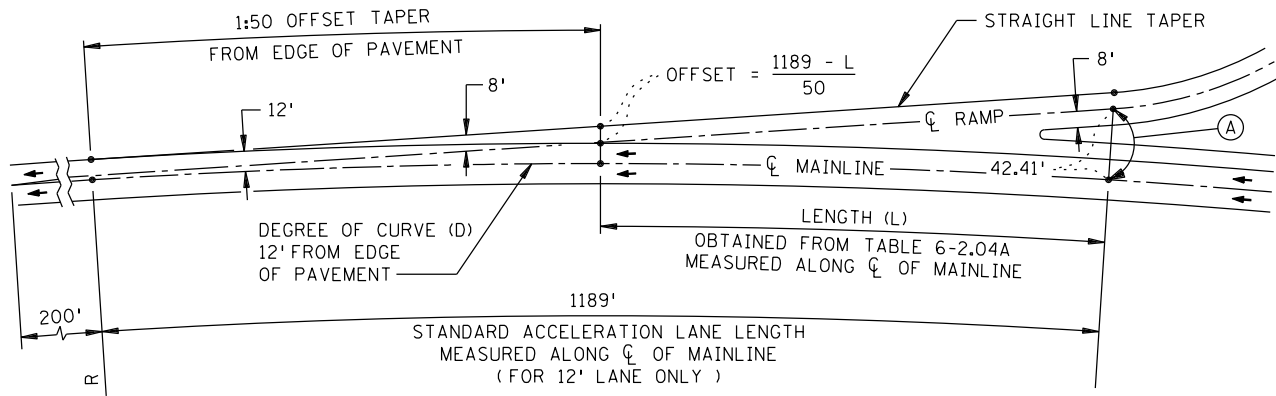

TAPERED ACCELERATION LANE ON OUTSIDE OF CURVING MAINLINE

Figure 6-2.04A

Table 6-2.04A

TAPERED ACCELERATION LANE ON OUTSIDE OF CURVING MAINLINE

ACCELERATION LANE LENGTH AND OFFSET VALUES

Degree of Curve (D)	Ramp Deflection Angle (A)	Length (L) (Feet)	Offset (Feet)
0° 7' 0"	2° 33' 10"	1188.87	0.0
0° 8' 0"	2° 38' 21"	1119.91	1.38
0° 9' 0"	2° 44' 46"	1055.77	2.66
0° 10' 0"	2° 49' 54"	1001.5	3.75
0° 11' 0"	2° 54' 47"	954.81	4.68
0° 12' 0"	2° 58' 27"	914.08	5.50
0° 13' 0"	3° 3' 55"	878.15	6.22
0° 14' 0"	3° 7' 13"	846.13	6.86
0° 15' 0"	3° 11' 22"	817.37	7.43
0° 16' 0"	3° 15' 22"	791.35	7.95
0° 17' 0"	3° 19' 15"	767.66	8.43
0° 18' 0"	3° 23' 2"	745.97	8.86
0° 19' 0"	3° 27' 42"	726.01	9.26
0° 20' 0"	3° 30' 16"	707.57	9.63
0° 21' 0"	3° 34' 45"	690.46	9.97
0° 22' 0"	3° 37' 9"	674.53	10.29
0° 23' 0"	3° 40' 28"	659.65	10.59
0° 24' 0"	3° 44' 43"	645.71	10.87
0° 25' 0"	3° 47' 54"	632.61	11.13
0° 26' 0"	3° 50' 2"	620.28	11.37
0° 27' 0"	3° 53' 5"	608.64	11.61
0° 28' 0"	3° 56' 5"	597.62	11.83
0° 29' 0"	3° 59' 2"	587.18	12.04
0° 30' 0"	4° 2' 56"	577.27	12.23
0° 32' 0"	4° 8' 35"	558.85	12.60
0° 34' 0"	4° 13' 4"	542.08	12.94

Degree of Curve (D)	Ramp Deflection Angle (A)	Length (L) (Feet)	Offset (Feet)
0° 36' 0"	4° 18' 23"	526.72	13.25
0° 38' 0"	4° 24' 33"	512.60	13.53
0° 40' 0"	4° 29' 34"	499.54	13.79
0° 42' 0"	4° 33' 29"	487.43	14.03
0° 44' 0"	4° 38' 16"	476.15	14.26
0° 45' 0"	4° 41' 37"	470.80	14.36
0° 46' 0"	4° 43' 56"	465.52	14.47
0° 48' 0"	4° 48' 31"	455.74	14.67
0° 50' 0"	4° 52' 59"	446.47	14.85
0° 54' 0"	5° 1' 41"	429.49	15.19
0° 58' 0"	5° 9' 3"	414.30	15.49
1° 0' 0"	5° 13' 7"	407.27	15.63
1° 2' 0"	5° 17' 7"	400.59	15.77
1° 6' 0"	5° 25' 56"	388.15	16.02
1° 10' 0"	5° 33' 31"	376.79	16.24
1° 15' 0"	5° 42' 40"	363.88	16.50
1° 20' 0"	5° 51' 31"	352.21	16.74
1° 25' 0"	5° 59' 5"	341.57	16.95
1° 30' 0"	6° 7' 24"	331.83	17.14
1° 35' 0"	6° 15' 29"	322.87	17.32
1° 40' 0"	6° 23' 20"	314.58	17.49
1° 45' 0"	6° 31' 0"	306.90	17.64
1° 50' 0"	6° 38' 28"	299.74	17.79
1° 55' 0"	6° 46' 46"	293.05	17.92
1° 58' 11"	6° 50' 19"	289.01	18.00

For values between those tabulated, use straight line interpolation

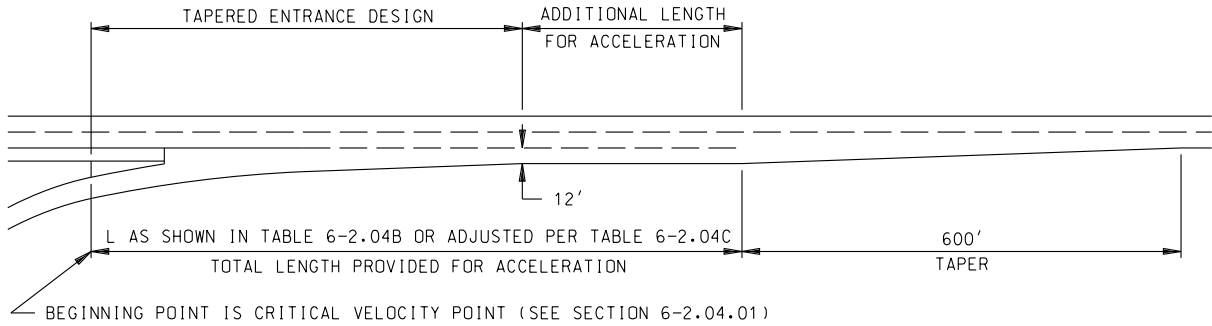

**ACCELERATION LANE TO TANGENT MAINLINE
TAPERED ENTRANCE DESIGN WITH ADDITIONAL ACCELERATION LENGTH
TO ALLOW ACCELERATION TO MAINLINE SPEED**

Figure 6-2.04B

**Table 6-2.04B
TOTAL LENGTHS FOR ACCELERATION FOR ENTRANCES ON FLAT GRADES
(2% OR LESS)* - MINIMUM VALUES**

DESIGN SPEED, MPH	SPEED REACHED (MPH)	L = ACCELERATION LENGTH (FT)									
		FOR ENTRANCE CURVE DESIGN SPEED (MPH)									
		STOP CONDITION	15	20	25	30	35	40	45	50	
		AND INITIAL SPEED (MPH)									
		0	14	18	22	26	30	36	40	44	
30	23	180	140	-	-	-	-	-	-	-	
35	27	280	220	160	-	-	-	-	-	-	
40	31	360	300	270	210	120	-	-	-	-	
45	35	560	490	440	380	280	160	-	-	-	
50	39	720	660	610	550	450	350	130	-	-	
55	43	960	900	810	780	670	550	320	150	-	
60	47	1200	1140	1100	1020	910	800	550	420	180	
65	50	1410	1350	1310	1220	1120	1000	770	600	370	
70	53	1620	1560	1520	1420	1350	1,230	1000	820	580	
75	55	1790	1730	1630	1580	1510	1420	1160	1040	780	

* For steeper grades, use Table 6-2.04C to adjust the lengths shown in this Table.

**Table 6-2.04C
ADJUSTMENT FACTORS FOR ACCELERATION LANES ON GRADE (>2%)**

Design Speed of Highway (mph)	Acceleration Lanes on Grade Adjustment Factors for Design Speed of Turning Roadway Curve (mph)				
	20	30	40	50	All Speeds
	3 to 4 percent upgrade				3 to 4 percent downgrade
40	1.3	1.3	-	-	0.7
50	1.3	1.4	1.4	-	0.65
60	1.4	1.5	1.5	1.6	0.6
70	1.5	1.6	1.7	1.8	0.6
	5 to 6 percent upgrade				5 to 6 percent downgrade
40	1.5	1.5	-	-	0.6
50	1.5	1.7	1.9	-	0.55
60	1.7	1.9	2.2	2.5	0.5
70	2.0	2.2	2.6	3.0	0.5

Multiply the factor from this Table by the length in Table 6-2.04B to get the length of acceleration lane on a grade.

6-2.06 Weaving

Weaving is defined as the crossing of two or more traffic streams traveling in the same general direction along a length of a highway, without the aid of traffic control devices. Weaving areas are formed when a merge area is closely followed by a diverge area, or when an on-ramp is closely followed by an off-ramp and the two are joined by an auxiliary lane.

The capacity and level of service calculations are made from the methodology presented in the Highway Capacity Manual (HCM). The methodology allows the determination of the appropriate length of the weaving section which will accommodate the predicted traffic conditions. They are:

1. Total weaving volume;
2. Total non-weaving volume;
3. Average running speed of weaving volume; and
4. Average running speed of non-weaving volume.

Important design elements which must be considered are:

1. The number of lanes in the weaving area;
2. The configuration of the section in terms of lane balance (i.e., the adding and dropping of auxiliary lanes);
3. The desired level of services; and
4. The speed of weaving vehicles, which should be within 5 mph of non-weaving vehicles to achieve acceptable operation.

All of the above factors must be properly considered in order to provide a weaving section design which will operate safely and efficiently.

The HCM provides the methodology for computation of the Level of Service (LOS) for a given weaving condition. The methodology is also available as Highway Capacity Software (HCS) and in the CORSIM software package.

There are three primary types of weaving areas which are determined by the operational features such as number of entry lanes, number of exit lanes, and their impact on how much lane-changing must take place. The three types of weave areas are Type A Weave Area, Type B Weave Area, and Type C Weave Area.

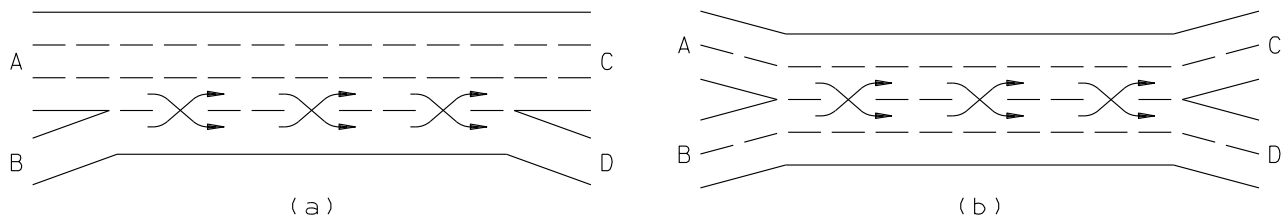

(a) RAMP-WEAVE/ONE-SIDED WEAVE, AND (b) MAJOR WEAVE WITH CROWN LINE.

CONFIGURATIONS FOR TYPE A WEAVING AREAS

Figure 6-2.06A

Type A Weave Areas require that each weaving vehicle make one lane change in order to execute the desired movement. The Type A Weave Area is also broken down into two distinct weave sections. The ramp-weave section shown in Figure 6-2.06A (a) is formed by an on-ramp/off-ramp sequence joined by a continuous auxiliary lane; it is called the one-side weaving section because all weaving movements take place on one side of the roadway. The other is the major weaving section shown in Figure 6-2.06A (b); it is characterized by three or more entry and exit roadways having multiple lanes. These two sections are similar in that each has a crown line, that is, a lane line which connects the noses of the entrance and exit gore areas.

Type B Weave Areas (see Figure 6-2.06B) are classified as major weaving sections because they all involve multi-lane entry and/or exit legs. The two critical characteristics that distinguish Type B weaving areas are:

1. One weaving movement may be accomplished without making any lane changes.
2. The other weaving movement requires, at most, one lane change.

Type B Weave Areas are extremely efficient in carrying large weaving volumes, primarily because of provisions of a through-lane for one of the weaving movements. Weaving maneuvers can be accomplished with a single lane change from the lane or lanes adjacent to this through-lane.

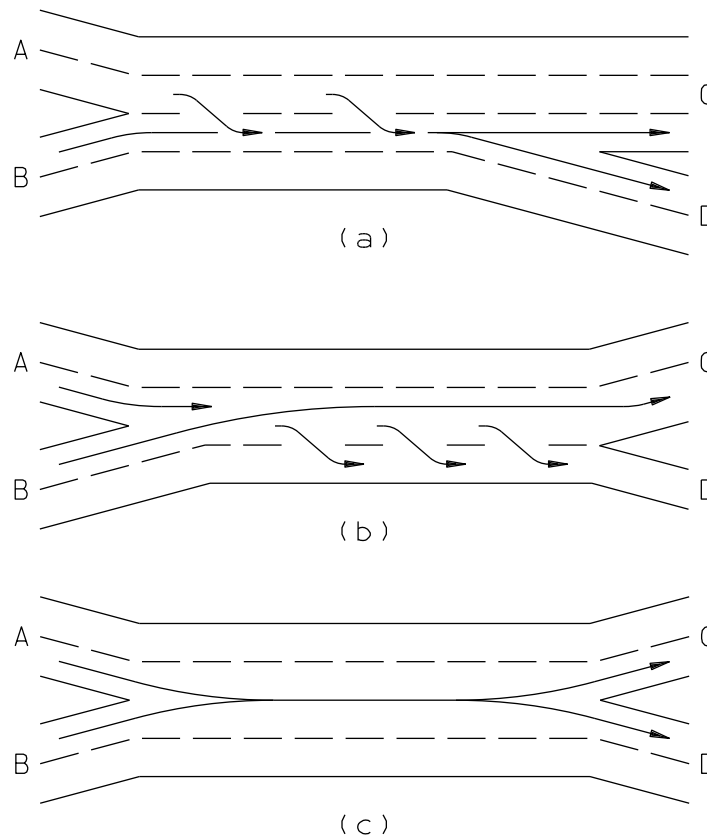

(a) MAJOR WEAVE WITH LANE BALANCE AT GORE, (b) MAJOR WEAVE WITH MERGING AT ENTRANCE GORE AND (c) MAJOR WEAVE WITH MERGING AT ENTRANCE GORE AND LANE BALANCE AT EXIT GORE.

CONFIGURATIONS FOR TYPE B WEAVING AREAS

Figure 6-2.06B

Type C Weave Areas (see Figure 6-2.06C) are similar to Type B sections in that one or more through lanes are provided for one of the weaving movements. The distinguishing difference between Type B and Type C weave areas is the number of lane changes required for the other weaving movement. A Type C Weave Area is characterized by:

1. One weaving movement may be accomplished without making a lane change.
2. The other weaving movement requires two or more lane changes.

It should be noted that the configuration shown in Figure 6-2.06C (b) is technically a Type C; however, per the HCM the developed weave methodology will give only a rough approximation of capacity. Generally, this weave configuration should be avoided in cases where there is any significant ramp-to-ramp volume.

Regardless of the calculations from the HCM or HCS, the length of weaving area should not be less than 1000 ft.

Preferably, the interchanges should be designed to eliminate weaving. However, this will undoubtedly result in higher construction costs. The user benefits must be weighed against the additional costs to determine if the elimination of weaving is worth the expense.

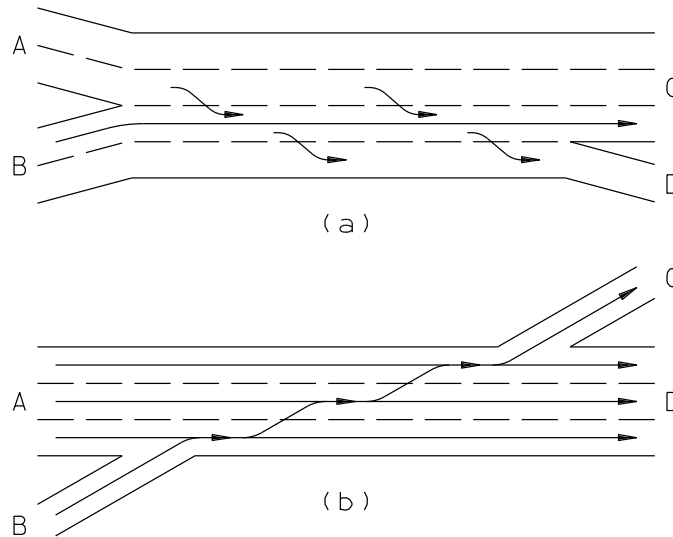

(a) MAJOR WEAVE WITHOUT LANE BALANCE OR MERGING, AND (b) TWO-SIDED WEAVE.

CONFIGURATIONS FOR TYPE C WEAVING AREAS.

Figure 6-2.06C

6-2.07 Ramp Controls

6-2.07.01 Policy

On-ramps to freeway type facilities in the Metro Area may be metered. Some of the metered ramps which carry buses and other High Occupancy Vehicles (HOV) may be provided with HOV bypass lanes. Ramp meters and HOV ramp bypass lanes are the most easily implemented freeway controls. Experience in Minnesota, and various national reports and circulars have shown that ramp metering reduces the disruptive effect of congestion and helps freeways operate at higher capacity. The HOV ramp bypass lanes are implemented for the purpose of giving a priority to the multi-passenger vehicles; they encourage car pooling while increasing the persons per mile use of the freeway.

6-2.08 Metered Ramps

Ramps may be metered as one lane, as two metered lanes, as two metered lanes with an HOV bypass, and as two metered lanes with a metered HOV bypass. The single lane metering applies only to retrofit situations where widening of a ramp or loop is not practical, and in some cases to new construction where the Traffic Management Center decided to implement one lane metering. In all other cases, a two lane metering of the on-ramps and loops shall be designed. All the foregoing discussion of various metered combinations is for a ramp that during the off-peak periods operates as a single lane ramp. Any two lane on-ramps which are metered, and any ramp-street junctions of metered ramps which receive double left turn movements are special cases requiring a special design.

6-2.08.01 System-to-System Metered Ramps

Normally, the system-to-system ramps are not metered. But if the Traffic Management Center determines that a particularly high volume ramp or a ramp system, when metered, will have improved operation, they may request that metering be implemented. Figure 6-2.09A shows the development of the system-to-system metered ramp and the HOV bypass lane.

6-2.08.02 Operational Criteria

The recommended basis for the operational criteria for metered ramps is as follows:

1. The majority of metered ramps and loops will operate as free flowing single lane ramps during the off-peak periods
2. During the metering phase of the operation, the majority of the metered ramps and loops should provide two lanes of vehicle storage up to the meter location. This is done for more efficient metering operation, maximized storage and driver expectation.
3. Generally, a six minute peak hour storage for the design hour desirably should be provided on all metered ramps.
4. The signal heads are to be placed approximately 500 ft (350 ft minimum) from the freeway-ramp junction nose. This distance, in conjunction with the acceleration lane portion, will allow most vehicles to approach mainline speeds before starting to merge with the traffic in the through lane.

6-2.08.03 Design Details

Single lane ramps and loops which will operate as two lane metered facilities should preferably have the following features in their design:

1. The roadway portion of the ramp preceding the ramp meter should be 22 ft wide. This width will adequately provide for two lane metering and still allow for one lane operation in the off-peak periods.
2. Rural design ramps and loops should maintain standard width shoulders in addition to the 22 ft wide pavement.
3. A minimum of 50 ft of uniform standard 16 ft ramp width, or 18 ft in the case of widened loops, should be provided at the ramp nose when tapering out the additional metered ramp width.

6-2.09 High Occupancy Vehicle (HOV) Ramp Bypass Lanes

HOV ramp bypasses give the HOV traffic at the ramp meters the advantage over single occupancy vehicles. HOV bypasses should be considered on all metered ramps. To conform to driver's expectation, HOV bypass lanes should be developed as follows:

1. Loops – Since the majority of drivers navigate to the inside of a sharp curve, and storage is difficult to accommodate on loops, the HOV bypass should be developed to the outside (driver's left) of the loop. With this design, the nose of the separating island will not be in the path of regular traffic. Therefore, during off peak periods, loops with HOV bypass will operate the same as loops without HOV bypass.
2. Right curving ramps with 6 deg. or sharper curves – the HOV bypass should be developed on the left side for the same reason listed in number 1 above.
3. Ramps with straight alignment, left curvature or right curvature that is flatter than 6 deg., the HOV bypass should be developed on the driver's right (see Figures 6-2.09A and B). This places the off peak traffic closer to the freeway side, which is consistent with driver's expectations.

6-2.09.01 HOV Bypass Design Criteria

1. The HOV bypass is designed to operate only during the time when the ramp is being metered. During off peak times, all traffic should use the main portion of the ramp. For this reason, the approach to the bypass should be designed such that a conscious effort has to be made by the driver entering the bypass, see Figure 6-2.09A.
2. A raised island up to 8 ft wide with B4 curb shall separate the HOV bypass from the main portion of the ramp.
3. Free right turns adversely affect the entrances to HOV bypasses. If practical, designers should consider eliminating the free right turn when an HOV bypass is constructed. Where double left turn lanes (to the on-ramp) and an HOV bypass are present, free right turns shall not be allowed. Figure 6-2.09C shows an HOV bypass lane when double left turn lanes are present.
4. The TMC should be contacted for input regarding queue length and storage.
5. If the projected peak traffic storage demand is such that an overflow from the storage area will block the entrance to the bypass lane, the storage length should be increased and additional lane width, striped as a diamond lane, should be provided. See Figure 6-2.09A, note 8.
6. The minimum recommended length of a ramp is 1300 ft. This length would allow entering vehicles to approach mainline speeds.

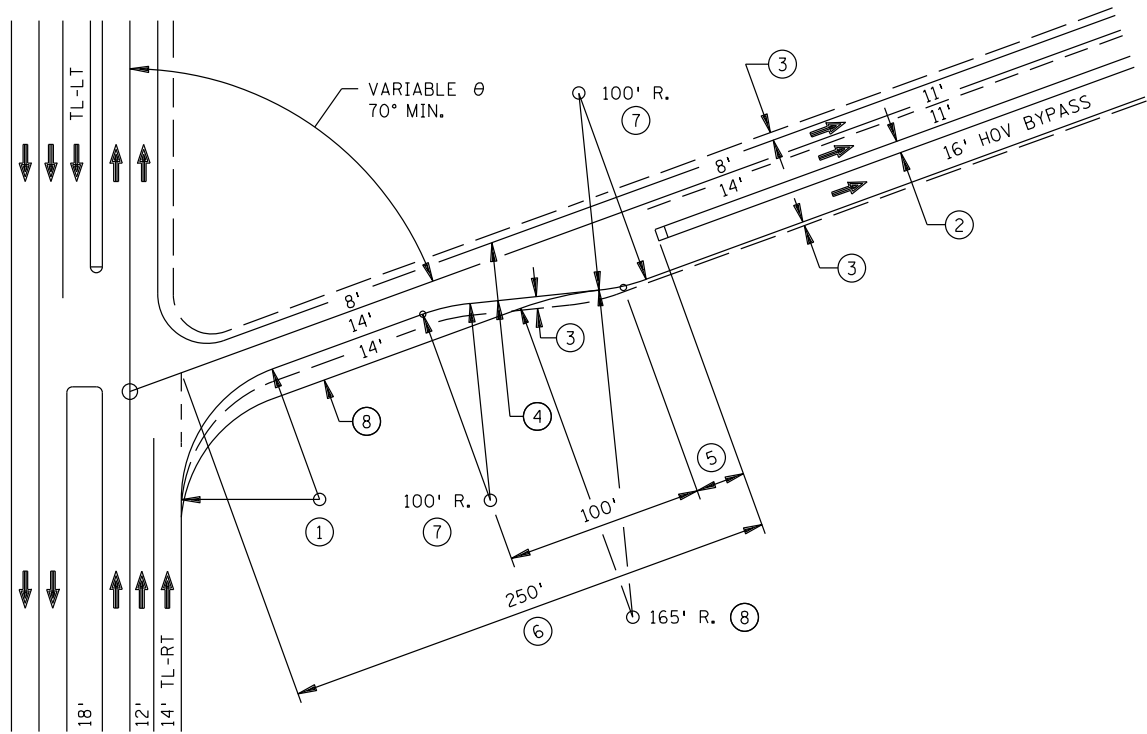

RAMP H.O.V. BYPASS DESIGN

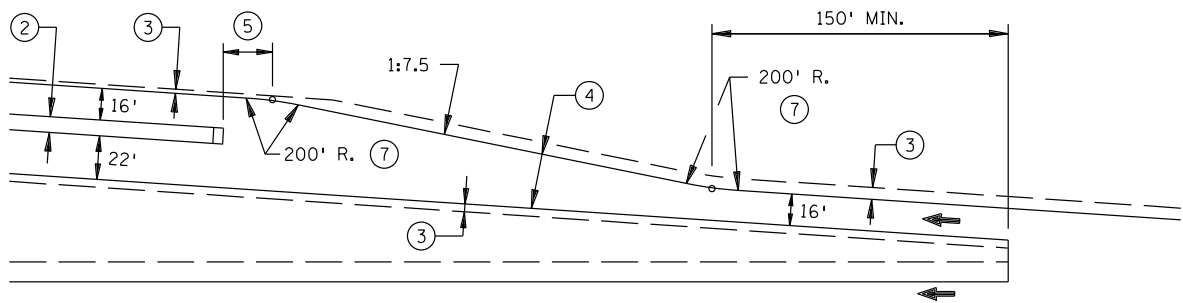

SYSTEM TO SYSTEM RAMP H.O.V. BYPASS DESIGN

- ① SEE CHAPTER FIVE "AT-GRADE INTERSECTIONS" FOR INTERSECTION DETAILS.
- ② USE A RAISED ISLAND UP TO 8' WIDE WITH B4 CURB ON ALL RAMPS.
- ③ FOR RURAL RAMP DESIGN PROVIDE: 6' RIGHT SHOULDER, 4' LEFT SHOULDER AND 2' H.O.V. RIGHT SHOULDER.
- ④ REPRESENTS D4 CURB LINE (GUTTER) IN URBAN DESIGN OR A STRIPE LINE IN RURAL DESIGN.
- ⑤ A TAPER P.I. 25' BACK OF THE RAISED MEDIAN NOSE.
- ⑥ 300' DIMENSION WHEN DEVELOPING RAMP TERMINAL WITH H.O.V. BYPASS FOR A DOUBLE LEFT TURNING MOVEMENT.
- ⑦ IN RURAL AREAS, THE RADII MAY BE OMITTED.
- ⑧ ON RAMPS AND LOOPS, WHEN ADEQUATE MINIMUM STORAGE CANNOT BE PROVIDED, PAVE ADDITIONAL LANE WIDTH AND STRIPE IT AS A DIAMOND LANE TO PROVIDE ADDITIONAL HOV BYPASS LENGTH.

RAMP HOV BYPASS
Figure 6-2.09A

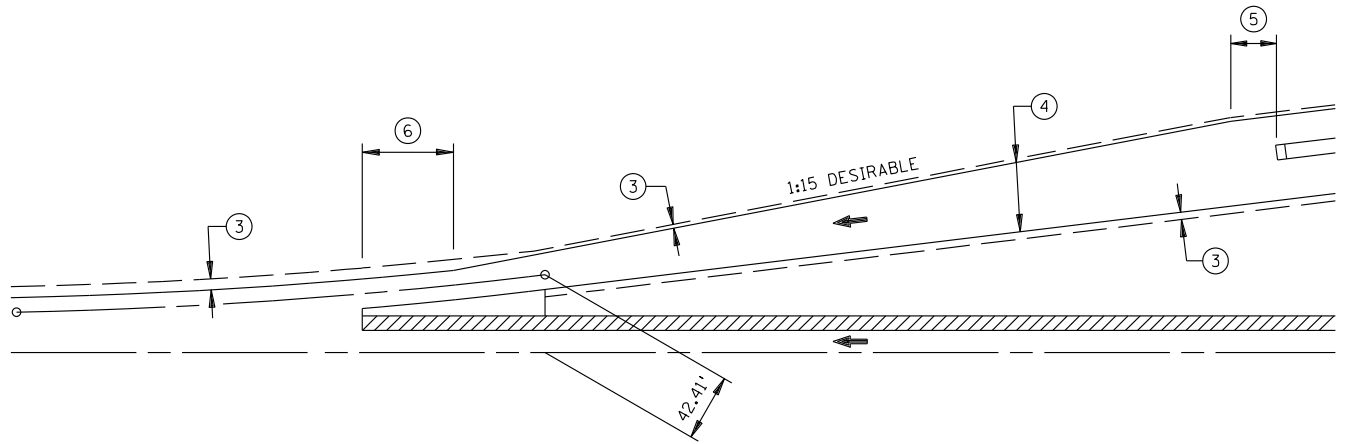

METERED RAMP AND H.O.V. BYPASS MERGE AREA DESIGN

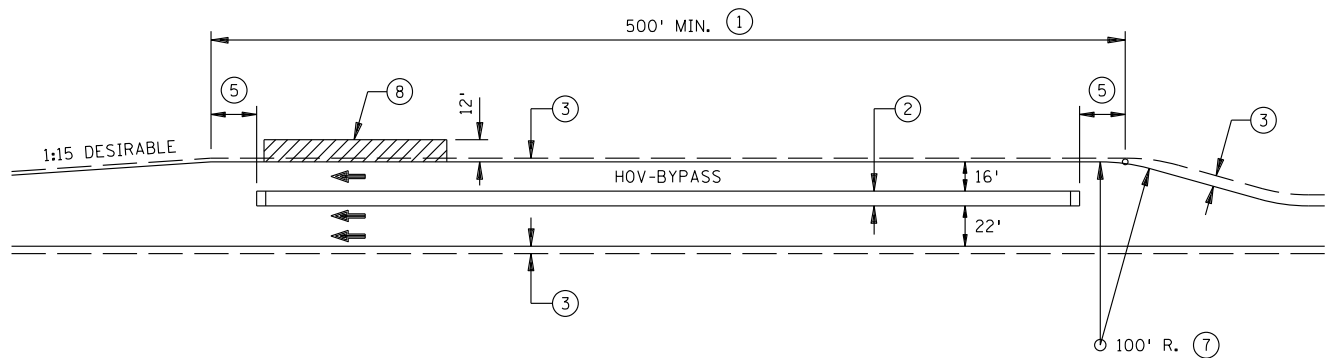

RAMP H.O.V. BYPASS DETAIL

- ① ADDITIONAL LENGTH MAY BE NEEDED FOR STORAGE. CONSULT TMC.
- ② USE A RAISED MEDIAN ISLAND UP TO 8' WIDE WITH B4 CURB.
- ③ FOR RURAL RAMP DESIGN PROVIDE: 6' RIGHT SHOULDER, 4' LEFT SHOULDER AND 2' H.O.V. RIGHT SHOULDER.
- ④ REPRESENTS 4" D CURB LINE (GUTTER) IN URBAN DESIGN OR A STRIPE LINE IN RURAL DESIGN.
- ⑤ A TAPER P.I. 25' BACK OF THE RAISED MEDIAN NOSE.
- ⑥ 50' MINIMUM UNIFORM RAMP WIDTH.
- ⑦ IN RURAL AREAS, THE RADIUS MAY BE OMITTED.
- ⑧ WHERE POSSIBLE, PROVIDE A 12' X 100' BITUMINOUS SHOULDER FOR THE STATE PATROL TO USE AS AN ENFORCEMENT AREA. THIS ENFORCEMENT AREA SHOULD BE LOCATED ADJACENT TO THE HOV BYPASS, AT THE END OF THE MEDIAN ISLAND.

RAMP HOV BYPASS AND MERGE AREA DETAILS

Figure 6-2.09B

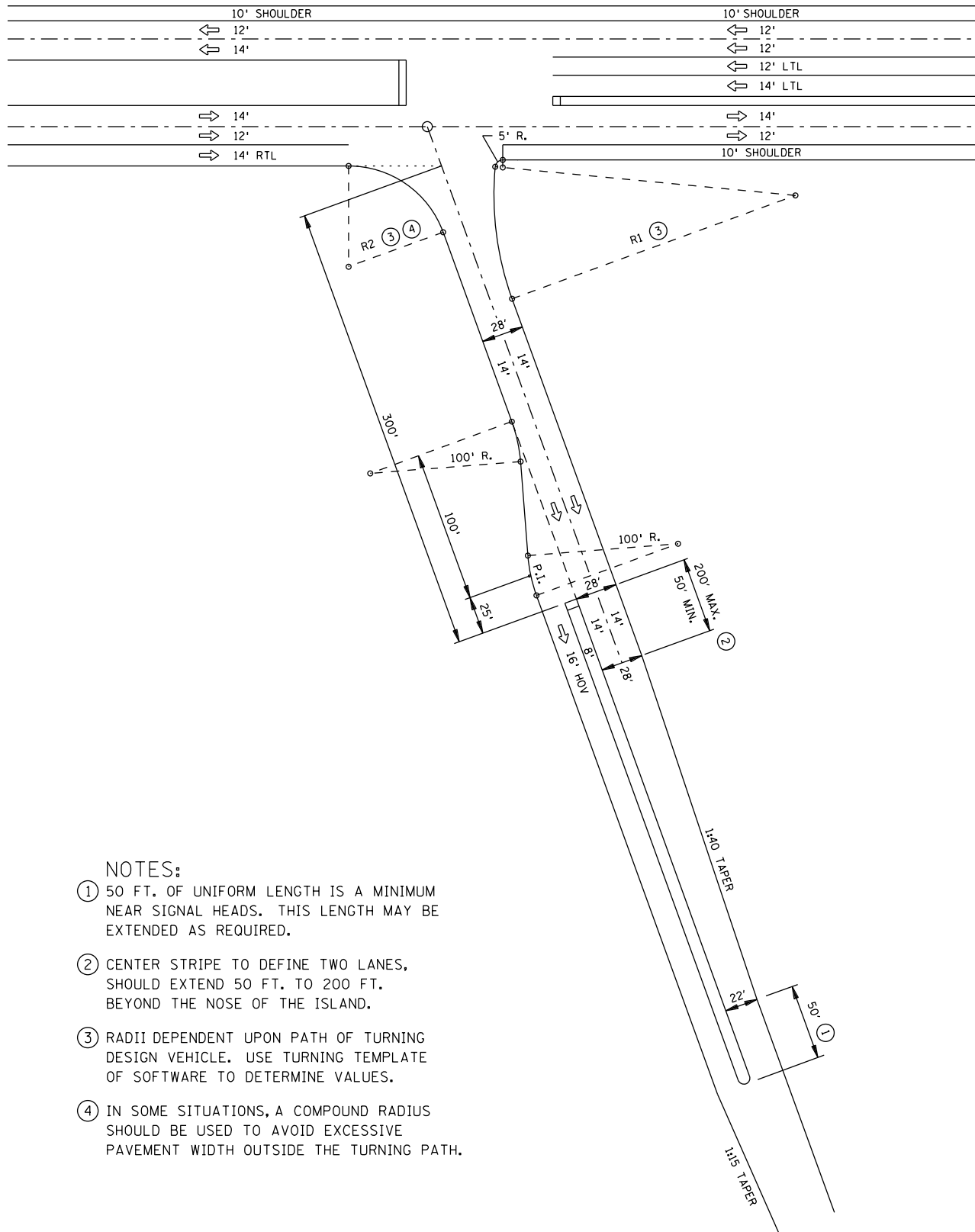

- NOTES:
- ① 50 FT. OF UNIFORM LENGTH IS A MINIMUM NEAR SIGNAL HEADS. THIS LENGTH MAY BE EXTENDED AS REQUIRED.
 - ② CENTER STRIPE TO DEFINE TWO LANES, SHOULD EXTEND 50 FT. TO 200 FT. BEYOND THE NOSE OF THE ISLAND.
 - ③ RADII DEPENDENT UPON PATH OF TURNING DESIGN VEHICLE. USE TURNING TEMPLATE OF SOFTWARE TO DETERMINE VALUES.
 - ④ IN SOME SITUATIONS, A COMPOUND RADIUS SHOULD BE USED TO AVOID EXCESSIVE PAVEMENT WIDTH OUTSIDE THE TURNING PATH.

DEVELOPMENT OF DOUBLE LEFT-TURN ON RAMP WITH HOV BYPASS LANE
Figure 6-2.09C

6-3.0 RAMP DESIGN**6-3.01 Policy (Urban/Rural)**

MnDOT has an urban and rural design for the ramp proper and the freeway/ramp junction. The basic difference is the use of delineator curbs on the urban design. The presence of curbs also affects the pavement width for the ramp. The preferred design is the rural design; however, the decision to use the urban or rural design will depend upon the character of the project area as a whole. Designs among the same roadway segment should preferably remain the same.

6-3.02 Types**6-3.02.01 Diagonal**

Diagonal ramps are used to provide right-turn movements at cloverleaf interchanges and both right- and left-turn movements at diamond interchanges. Figures 6-3.02A and B illustrate the diagonal ramp design at rural and urban diamond interchanges. The individual design elements are discussed in Section 6-3.04. At cloverleaf interchanges where a diagonal ramp may be outside of a loop, the diagonal ramp may follow a basic tangent alignment, a flat continuous curve alignment, or a reverse curve alignment. The determining factors will likely be the availability of right-of-way and the design speed of the ramp.

6-3.02.02 Loops

Loops are used at full or partial cloverleaf interchanges. They may serve only left-turning traffic or may serve both left and right turns where the ramp connecting road terminal is an at-grade intersection at right angles. The loop usually involves more indirect travel than other ramp types: the driver must travel beyond the crossing highway, exit onto the loop ramp, and make a 270-deg turn to reach the crossroad. The restricted geometry of a loop complicates acceleration and deceleration maneuvers onto and from the mainline.

6-3.02.03 Semi-Direct

A semi-direct ramp involves a driver initially turning right away from the intended direction, negotiating a reverse curve, and then traveling in a curvilinear path to the left before merging with the crossing road. This ramp is only used for left turns. It is also called a "jug-handle" ramp. In terms of travel distance, semi-direct ramps fall between a loop and direct ramp. Its use requires at least three structures or a 3-level structure.

6-3.02.04 Direct

Direct ramps are used at directional interchanges, although in a strict sense diagonal ramps are also direct ramps. The alignment of direct ramps is characterized by little or no deviation from the intended direction of travel. Direct ramps involve the least travel distance and highest speed of all ramp types used to accommodate left-turning traffic. They result in high levels of service, eliminate weaving, and offer the greatest operational safety advantage. However, the use of direct ramps also involves the most complicated and expensive interchange structures.

6-3.03 Capacity

The capacity of a ramp depends on the free flow speed of the ramp. Refer to the [Highway Capacity Manual](#) for guidance.

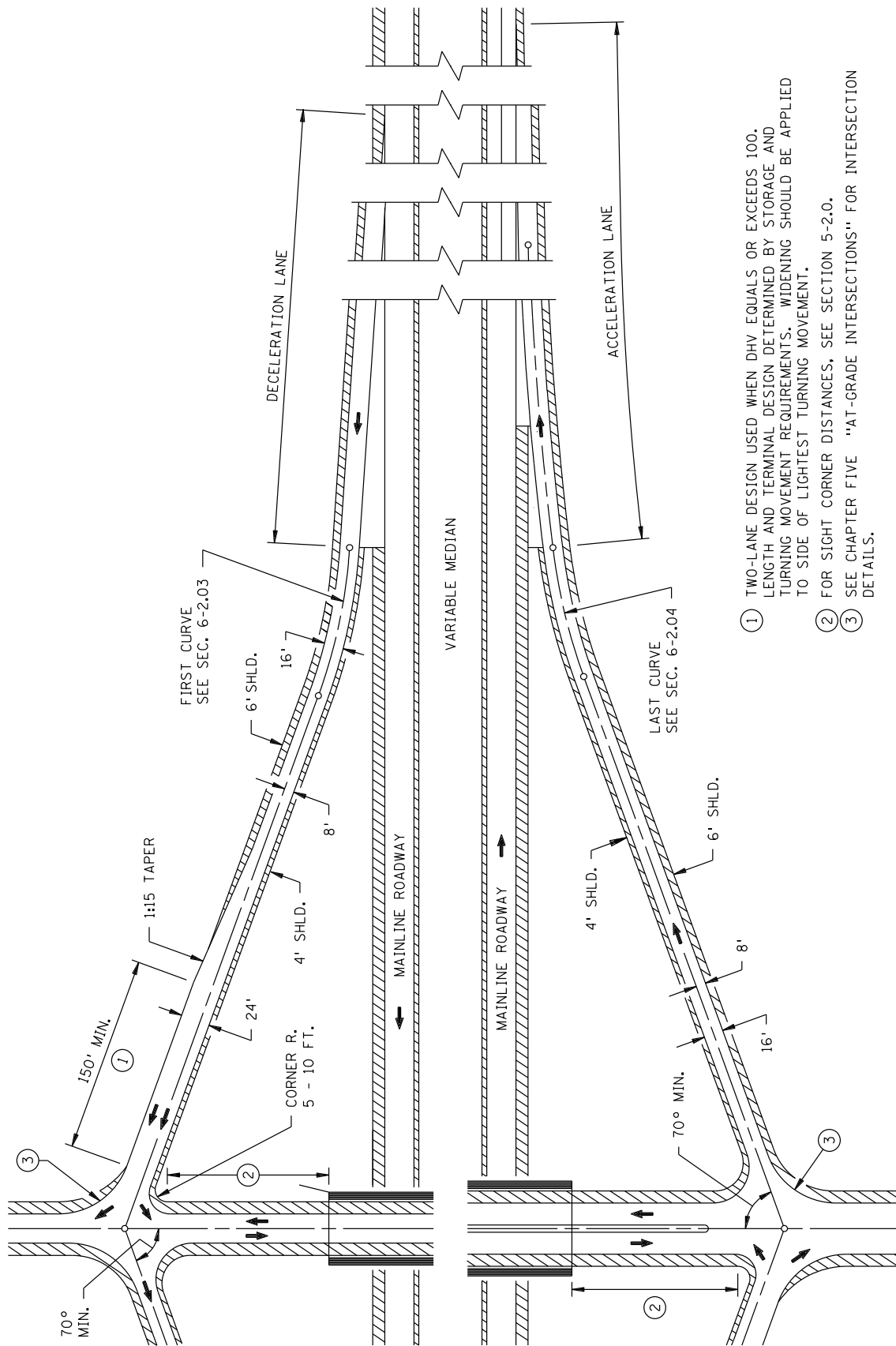

- ① TWO-LANE DESIGN USED WHEN D.V. EQUALS OR EXCEEDS 100. LENGTH AND TERMINAL DESIGN DETERMINED BY STORAGE AND TURNING MOVEMENT REQUIREMENTS. WIDENING SHOULD BE APPLIED TO SIDE OF LIGHTEST TURNING MOVEMENT.
- ② FOR SIGHT CORNER DISTANCES, SEE SECTION 5-2.0.
- ③ SEE CHAPTER FIVE "AT-GRADE INTERSECTIONS" FOR INTERSECTION DETAILS.

**DIAGONAL RAMP DESIGN
DIAMOND INTERCHANGE - RURAL**
Figure 6-3.02A

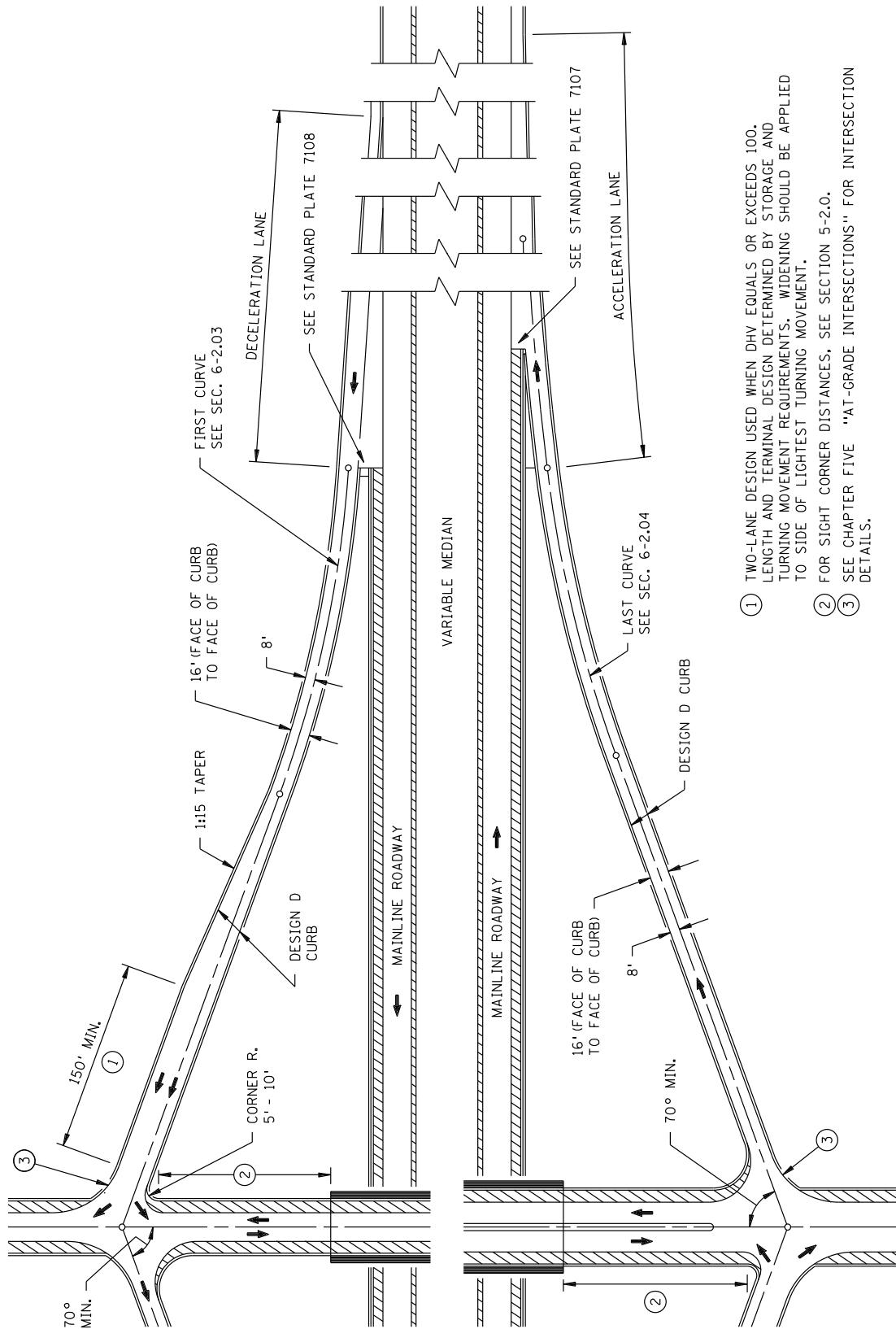

- ① TWO-LANE DESIGN USED WHEN DHV EQUALS OR EXCEEDS 100. LENGTH AND TERMINAL DESIGN DETERMINED BY STORAGE AND TURNING MOVEMENT REQUIREMENTS. WIDENING SHOULD BE APPLIED TO SIDE OF LIGHTTEST TURNING MOVEMENT.
- ② FOR SIGHT CORNER DISTANCES, SEE SECTION 5-2.0.
- ③ SEE CHAPTER FIVE "AT-GRADE INTERSECTIONS" FOR INTERSECTION DETAILS.

DIAGONAL RAMP DESIGN
DIAMOND INTERCHANGE - URBAN
 Figure 6-3.02B

6-3.04 Design Elements**6-3.04.01 Design Speed**

The design speed of the ramp proper should conform to the expectations of drivers and fit the constraints and topography of each location. In practice this involves designing the curve adjoining the mainline terminal to a certain percentage of the mainline design speed, depending on context, degree of constraint, and construction cost. The other portions of the ramp are designed based loosely on an assumed speed profile along its length. For ramps that terminate at an intersection, uniform deceleration to a stop condition is usually appropriate. Direct and outer connections are most often designed for a constant speed. For semi-direct connections, the portion between the mainline terminals is usually designed to a somewhat lower speed than the terminal curves, typically dictated by site specifics and interchange configuration.

For a given mainline design speed, Table 6-3.04A gives the corresponding ranges of ramp design speed and associated minimum radius, applicable to the first/last curve adjoining the mainline terminal (but not the transitional curves to/from the main curve).

1. On diagonal ramps (such as ramps in diamond or parclo interchanges), the minimum design speed is the value from the lower range of Table 6-3.04A. In all but the most constrained situations (buttonhook configurations and urban core locations, for example), the desirable minimum design speed is the value from the middle range of the same table. To avoid excessive interchange footprints, design speeds in the high range are not recommended for diagonal ramps having reversing curvature, particularly those in parclos.
2. For loops, AASHTO recommends a design speed no less than 20 mph (110-ft radius) for use with high-speed highways and encourages above-minimum designs in less constrained locations. Radii between 140 ft (22.5 mph) and 170 ft (25 mph) have exhibited good performance with typical freeway design speeds (50 mph to 70 mph) where spiral or robust circular transition treatments are used (see 6-3.04.02). A maximum practical radius is 250 ft (30 mph), above which space requirements and travel times become excessive.
3. On semi-direct connections (as shown in Figure 6-1.03K) as well as outer connections in cloverleaf and semi-directional interchanges, the minimum design speed is the value from the middle range of Table 6-3.04A. This also applies to two-lane semi-direct connections.
4. A direct connection (as shown in Figure 6-1.03L) often carries a mainline route or has comparable significance or traffic demand. In these cases, a uniform design speed along its entire length based on guidelines for mainline highways may be appropriate. A value somewhat lower than for an open-road condition is often justified, however, to fit configuration and constraint. The minimum design speed for any direct connection is the value from the middle range of Table 6-3.04A, not less than 40 mph.

Refer to Chapter 3 for criteria pertaining to superelevation rates and transitions. Generally apply superelevation to the first/last curve per Table 3-3.02A and the selected ramp design speed; however, curves less than 200 feet in length may be sloped at the normal cross slope rate to avoid near-continuous transitioning through the curve. To simplify design, secondary curves on diagonal ramps should be superelevated only as necessary to limit side friction to f_{\max} , based on Figure 3-3.03A and an assumed speed at that point on the ramp. Loops should always receive full superelevation (0.06 to 0.08 (ft/ft, m/m)).

**Table 6-3.04A
RAMP DESIGN SPEEDS**

Highway Design Speed (mph)	40	45	50	55	60	65	70	75
Ramp Design Speed (mph)								
High Range (85%)	35	40	45	50	50	55	60	65
Middle Range (70%)	30	30	35	40	45	45	50	55
Low Range (50%)	20	22.5	25	27.5	30	30	35	40
Corresponding Minimum Radius (ft) Based on 0.08 (ft/ft) Maximum Superelevation								
High Range	350	465	600	760	760	960	1,200	1,500
Middle Range	250	250	350	465	600	600	760	960
Low Range	110	140	170	210	250	250	350	465

6-3.04.02 Horizontal Alignment

Horizontal alignment will be largely determined by the selected design speed. The minimum radii given in Table 6-3.04A are computed based on the values of maximum side friction for rural roadways presented in Table 3-2.03A; the values therein should be extrapolated for design speeds under 30 mph (50 km/h). Ramps and loops are to be designed using these rural side friction values regardless of the cross section design (rural or urban). All ramps should be as directional and flat-curved as possible. This applies, for example, on diagonal ramps at cloverleaf interchanges. The diagonal ramp should be as directional as possible, but may be allowed to follow a reverse curve path around the loop if site conditions are restrictive. Loops pose particular problems. The preferred design is to provide a 3-centered compound curve, the center curve being the minimum radius. The arrangement may be symmetrical or asymmetrical as may be appropriate for any variance in design speed between the two intersecting highways. A 3-centered arrangement allows for a transition between the mainline to the sharpest part of the loop curve, and it eases the acceleration and deceleration problems at either ramp end. For ramps and loops, the ratio of the flatter radius to the sharper one should not exceed 2:1. The length of the flatter transition curve should allow for a desirable acceleration/deceleration rate of 2 mph/sec (3 km/h/sec), and a minimum rate of 3 mph/sec (5 km/h/sec). It is also acceptable to provide a loop of constant-radius curvature. Desirable stopping sight distances should be used to check horizontal curvature. The values and the methodology are presented in Section 3-2.0. The desirable first curve of an exit ramp and the last curve of the entrance ramp are described in Sections 6-2.03 and 6-2.04. See Figure 6-2.03C.

6-3.04.03 Vertical Alignment

Maximum grades for vertical alignment cannot be as definitely expressed as for highway mainline, but preferably should not exceed 5 percent. General values of limiting gradient for ramps are shown in Table 6-3.04B, but for any one ramp the gradient to be used is dependent upon a number of factors peculiar to that site and quadrant alone. These factors include the following:

1. The flatter the gradient on the ramp, the longer it will be.
2. The steepest gradients should be designed for the center part of the ramp. Landing areas or storage platforms at at-grade intersections with ramps should be as flat as possible, as discussed in Section 5-2.02.
3. Short upgrades of 7 to 8 percent permit safe operation without unduly slowing down passenger cars. Short upgrades of up to 5 percent do not unduly affect trucks and buses.
4. Downgrades on ramps should follow the same guidelines as upgrades. They may, however, safely exceed these values by 2 percent, with 8 percent considered the desired maximum.
5. Ramp gradients and length can be significantly impacted by the angle of intersection between the two highways and the direction and amount of gradient on the two mainlines.

Ramp profiles usually have vertical curves at either end, with a straight grade in the center portion. The vertical curves should have designs which meet the criteria for desirable stopping sight distance as presented in Section 3-4.0. If vertical curves are designed at the mainline/ramp junctions, they should meet the design speed of the ramp.

**Table 6-3.04B (U.S. Customary)
RAMP GRADIENT GUIDELINES**

RAMP DESIGN SPEED (mph)	15	20	25	30	35	40	45	50
MAXIMUM GRADE (%)	8	8	7	7	6	6	5	5

**Table 6-3.04B (Metric)
RAMP GRADIENT GUIDELINES**

RAMP DESIGN SPEED (km/h)	30	40	50	60	70	80
MAXIMUM GRADE (%)	8	7	7	6	5	5

6-3.04.04 Cross Section

The lane and shoulder width are determined by the ramp's urban or rural character and its horizontal curve radius. Table 6-3.04C provides the necessary information.

Figures 6-3.04A and B illustrate the various ramp and loop cross section elements of pavement width, curbs, cross slope, side slope, and various pavement designs. Ramp and loop superelevation rates and transition should be as determined in Section 3-3.0. Where D4 curb and gutter is designated, the gutter slope should be the same as the adjacent pavement slope. Striping locations should be in accordance with Chapter 7 of the current MnDOT Traffic Engineering Manual and Part 3 of the current Minnesota Manual on Uniform Traffic Control Device (MN MUTCD).

**Table 6-3.04C (Metric)
RAMP PAVEMENT WIDTH¹**

		Width (m)	
RURAL²	Ramp	7.8	
	Loop	8.4	
URBAN³	Ramp or Loop	Radius (m)	Width (m)
		>150	4.8
		90-150	5.4
		70-<90	6.0
		58-<70	6.3
		48-<58 ⁴	6.6
38-<48 ⁴	7.2		

- 1) If ramp metering is anticipated, refer to Section 6-2.08 for design details.
- 2) Includes 1.8 m right shoulder and 1.2 m left shoulder.
- 3) Face-of-Curb to Face-of-Curb Width.
- 4) Radii indicated do not satisfy the minimum criterion presented in Section 6-3.04.01 and should be used only where constraints dictate.

**Table 6-3.04C (English)
RAMP PAVEMENT WIDTH¹**

		Width (ft)	
RURAL²	Ramp	26	
	Loop	28	
URBAN³	Ramp or Loop	Radius (ft)	Width (ft)
		>500	16
		300-500	18
		230-<300	20
		190-<230	21
		160-<190 ⁴	22
125-<160 ⁴	24		

- 1) If ramp metering is anticipated, refer to Section 6-2.08 for design details.
- 2) Includes 6 ft right shoulder and 4 ft left shoulder.
- 3) Face-of-Curb to Face-of-Curb Width.
- 4) Radii indicated do not satisfy the minimum criterion presented in Section 6-3.04.01 and should be used only where constraints dictate.

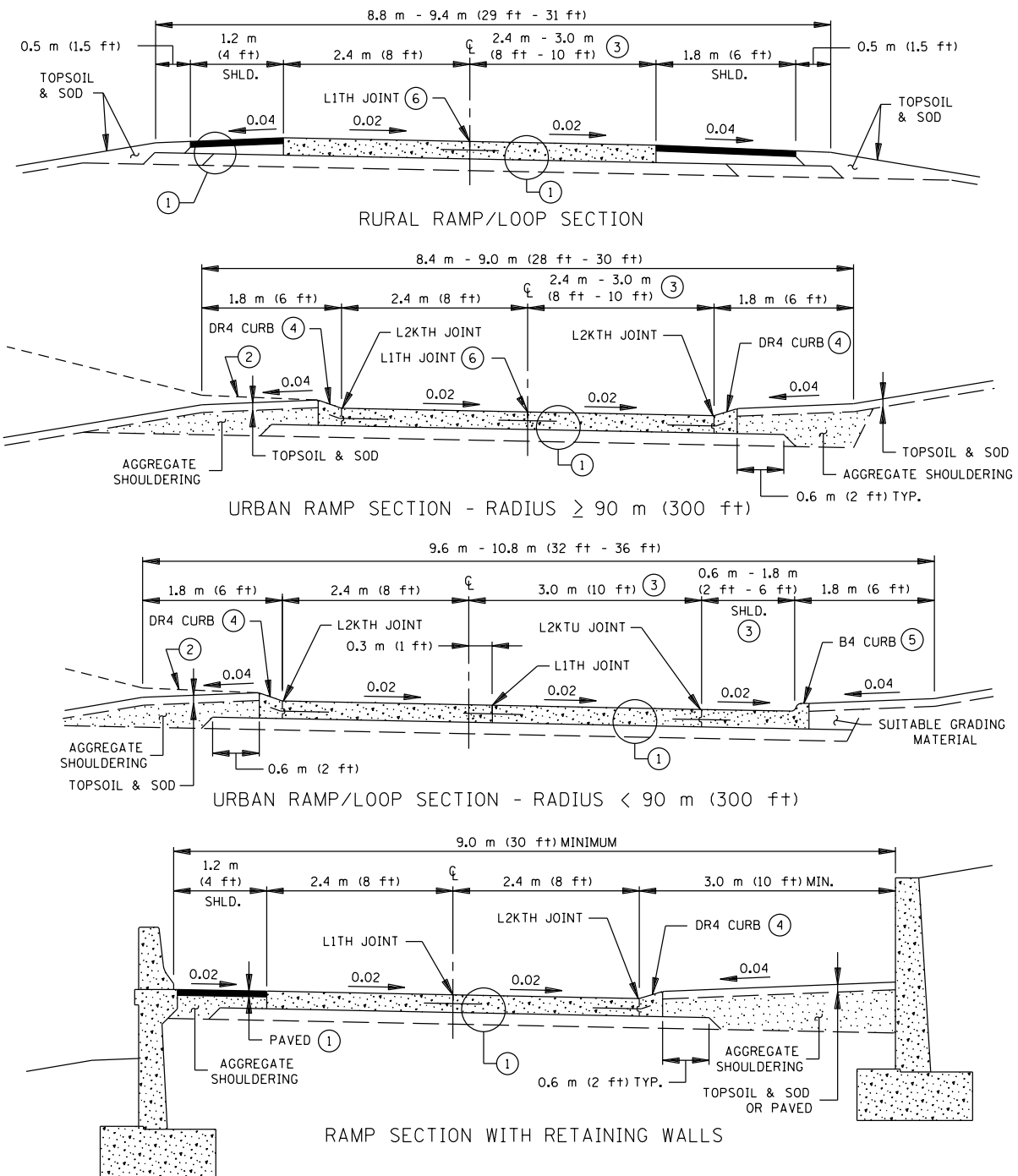

- ALL SLOPES ARE SHOWN IN m/m (ft/ft).
- ① FOR STRUCTURAL DESIGN OF PAVEMENTS, SEE CHAPTER 7 OF THE ROAD DESIGN MANUAL AND THE GEOTECHNICAL AND PAVEMENT MANUAL.
 - ② A CUT SLOPE IS PERMISSIBLE; HOWEVER, A TOE DITCH ON THE HIGH SIDE OF SUPERELEVATION IS DESIRABLE. REFER TO 4-6.03.01 AND FIGURE 4-6.03A FOR DESIGN CONSIDERATIONS.
 - ③ ALL NECESSARY RAMP/LOOP WIDENING SHOULD TYPICALLY BE ADDED TO THE INSIDE OF THE CURVE. REFER TO TABLE 6-3.04C FOR REQUIRED PAVEMENT WIDTHS.
 - ④ THE CONTRACTOR SHALL HAVE THE OPTION TO CONSTRUCT D4 INTEGRANT CURB IN LIEU OF DR4 CURB WITH L2KTH JOINT.
 - ⑤ CONSTRUCT B424 C & G FOR 0.6 m (2 ft) SHOULDER WIDTH, CONSTRUCT B436 C & G FOR 0.9 m (3 ft) SHOULDER WIDTH, CONSTRUCT INTEGRANT CURB FOR 1.2 m (4 ft) SHOULDER WIDTH OR GREATER (SAME PAVEMENT SECTION AND CROSS SLOPE AS LANE).
 - ⑥ WHERE 5.4 m (18 ft) CONCRETE PAVEMENT IS CONSTRUCTED, JOINT SHOULD BE LOCATED OFFSET 0.3 m (1 ft) RIGHT OF RAMP CENTERLINE.

TYPICAL RAMP SECTIONS – RIGID DESIGN
Figure 6-3.04A (Dual Units)

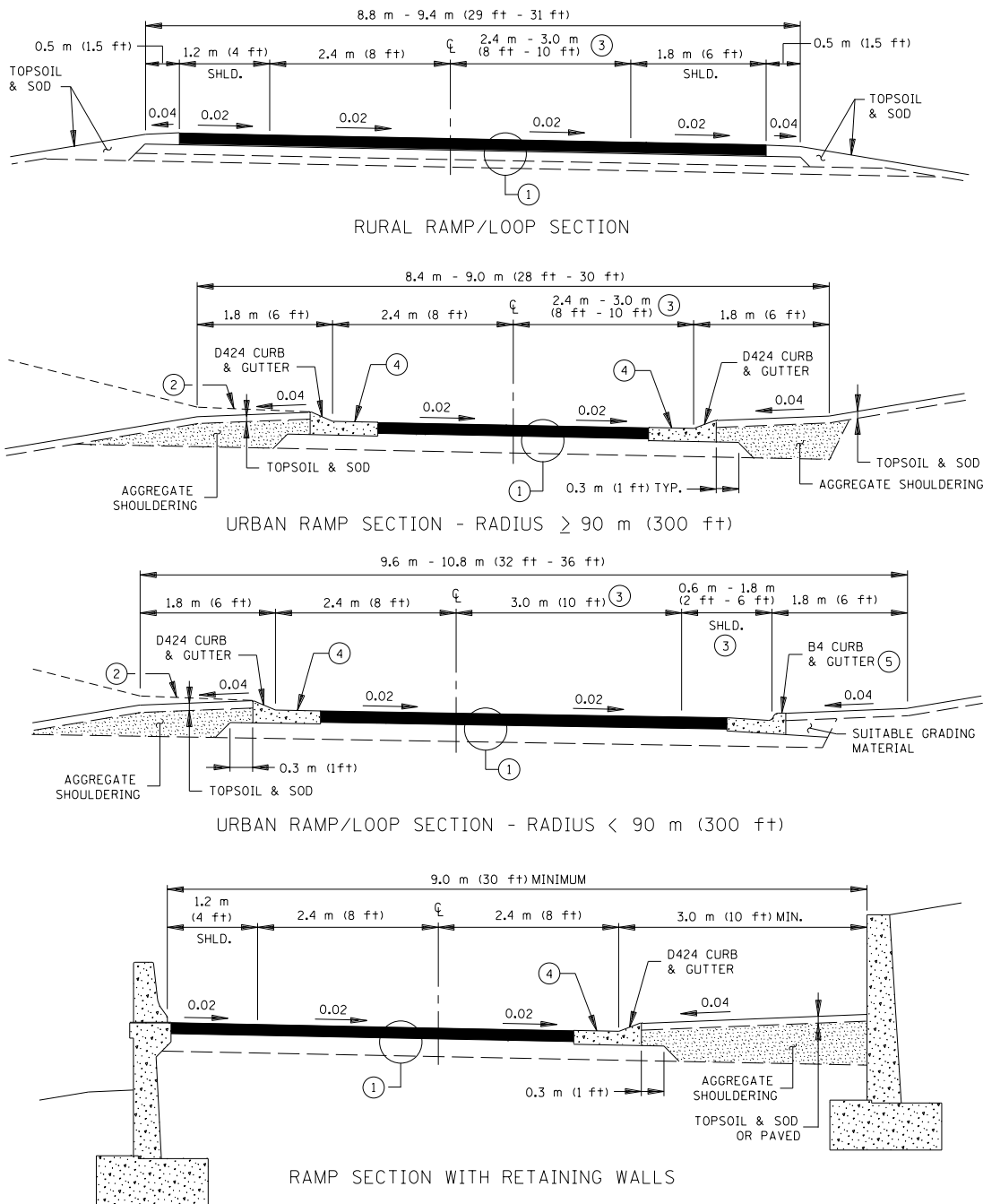

ALL SLOPES ARE SHOWN IN m/m (ft/ft).

- ① FOR STRUCTURAL DESIGN OF PAVEMENTS, SEE CHAPTER 7 OF THE ROAD DESIGN MANUAL AND THE GEOTECHNICAL AND PAVEMENT MANUAL.
- ② A CUT SLOPE IS PERMISSIBLE; HOWEVER, A TOE DITCH ON THE HIGH SIDE OF SUPERELEVATION IS DESIRABLE. REFER TO 4-6.03.01 AND FIGURE 4-6.03A FOR DESIGN CONSIDERATIONS.
- ③ ALL NECESSARY RAMP/LOOP WIDENING SHOULD TYPICALLY BE ADDED TO THE INSIDE OF THE CURVE. REFER TO TABLE 6-3.04C FOR REQUIRED PAVEMENT WIDTHS.
- ④ MATCH GUTTER SLOPE TO ADJACENT PAVEMENT CROSS SLOPE. GUTTER WIDTH IS INCLUDED AS PART OF RAMP TRAVELED WAY WIDTH.
- ⑤ WHERE 0.9 m (3 ft) SHOULDER WIDTH IS REQUIRED, USE B436 C & G; IN ALL OTHER CASES, USE B424 C & G.

TYPICAL RAMP SECTIONS – FLEXIBLE DESIGN
Figure 6-3.04B (Dual Units)

6-4.0 RAMP AND MINOR ROAD JUNCTION

6-4.01 General

At service interchanges, the ramp or loop normally intersects the minor road at-grade at approximately a 90 degree angle. This intersection should be treated as described in Chapter Five, "At-Grade Intersections." This will involve a consideration of the appropriate traffic control devices, capacity, and the physical geometric design elements such as sight distance, angle of intersection, grade, channelization, and turning lanes. Two points warrant special attention in the design of the ramp/minor road intersection:

1. Capacity - In urban areas where traffic volumes may be high, inadequate capacity of the ramp/minor road intersection can adversely affect the operation of the ramp/freeway junction. In a worst case situation, the safety and operation of the mainline itself may be impaired. Therefore, special attention should be given to providing sufficient capacity and storage for an at-grade intersection or a merge with the minor road. This could lead to the addition of lanes at the intersection or on the ramp proper such as free right, double left, double right or a combination thereof. It may involve advanced signalization where the ramp traffic is given priority. The analysis must also consider the operational impacts on the intersecting roads. The latest Highway Capacity Manual should be used to calculate capacity and level of service for the ramp/minor road intersections.
2. Sight distance - Section 5-2.0 discusses the procedure for addressing sight distance at the at-grade intersections. This procedure should be used for the ramp/minor road intersection. However, special attention must be given to the location of the bridge rail, pier or abutment because these will present major sight distance obstacles. The Case IIIB and IIIC methodology for left-turning vehicles presented in Section 5-2.0 should be used to determine if adequate sight distance is available. The combination of the bridge obstruction and the needed sight distance may result in relocating the ramp/minor road intersection to provide the needed sight distance.

The design of the minor road, if a county or municipal road, will be in accordance with the criteria and procedures presented in the State Aid Manual where appropriate.

6-4.02 Frontage Road Intersections

The separation between the mainline and the frontage road along the length of the facility, called the outer separation, is shown as X in Figure 6-4.02A. The desirable minimum value of X is 50 ft. However, in very restricted R/W areas, a concrete barrier and the shoulders of each roadway may be used for separation.

The distance separating the ramp/minor road intersection from the frontage road/minor road intersection is shown as Y in Figure 6-4.02A. Y should be wide enough to: allow the two intersections to operate independently, and eliminate the operational and signing problems of providing the same point of exit and entrance for the frontage road and freeway ramp.

At a minimum, a Y value of 780 ft is needed to accommodate back-to-back left turn lanes between the mainline and the frontage road. Refer to Chapter 2, Figures 2-3.06A, C, and D, and contact MnDOT's Access Management Unit for additional guidance. Figure 2-3.06B illustrates a design for a "ramp acceleration and merge" with a frontage road intersection downstream from the merge. In urban areas, when due to R/W constraints, it is not possible to make Y wide enough to develop full right turn lanes, a minimum of 300 ft separation should be provided. If a 300 ft separation is not available, the following design applications may be considered:

1. One-way frontage road - Figure 6-4.02B provides the basic schematic for the layout, and Figure 6-4.02C provides the design details for the merging and the diverging operations for the frontage road and ramp. The critical design element is the distance "A" between the ramp/frontage road merge and the minor road. This distance must be sufficient to allow traffic weave, vehicle deceleration and stop, and vehicle storage to avoid interference with the merge point. No points of access can be allowed in this section. Table 6-4.02A presents general guidelines which may be used to estimate this distance during the preliminary design phase. A number of assumptions have been made including weaving volume, operating speeds, and intersection queue distance. Therefore, a detailed design will be necessary to firmly establish the needed distance to properly accommodate traffic volumes and speed, weaving, stopping, and intersection storage.

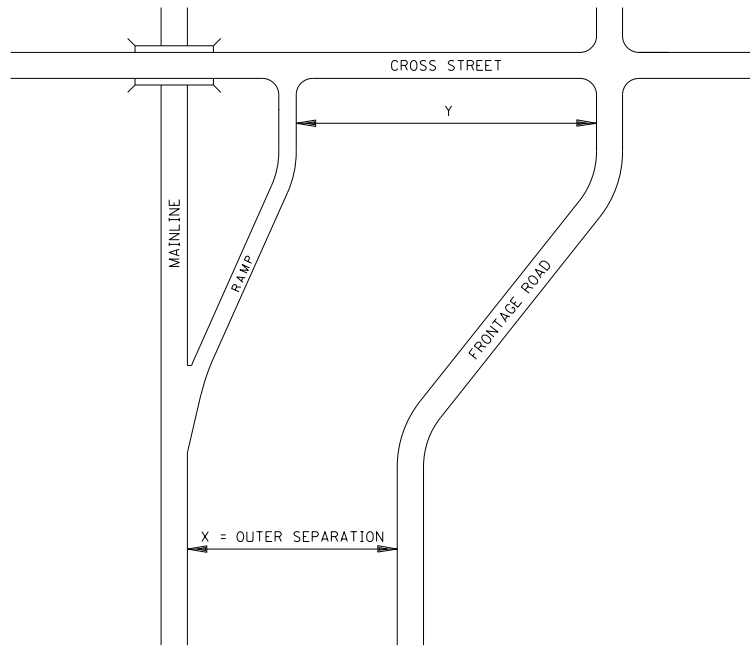

FRONTAGE ROAD DESIGN
Figure 6-4.02A

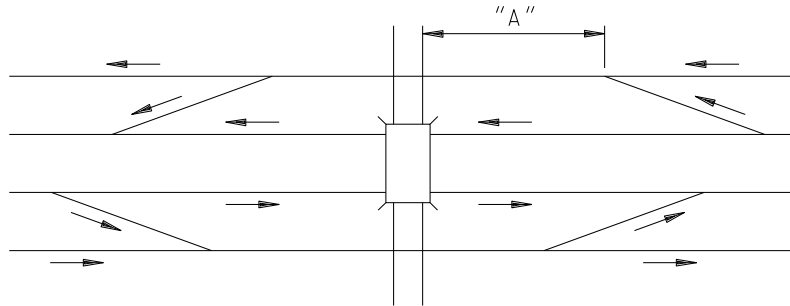

ONE-WAY FRONTAGE ROAD
SEE TABLE 6-4.02A

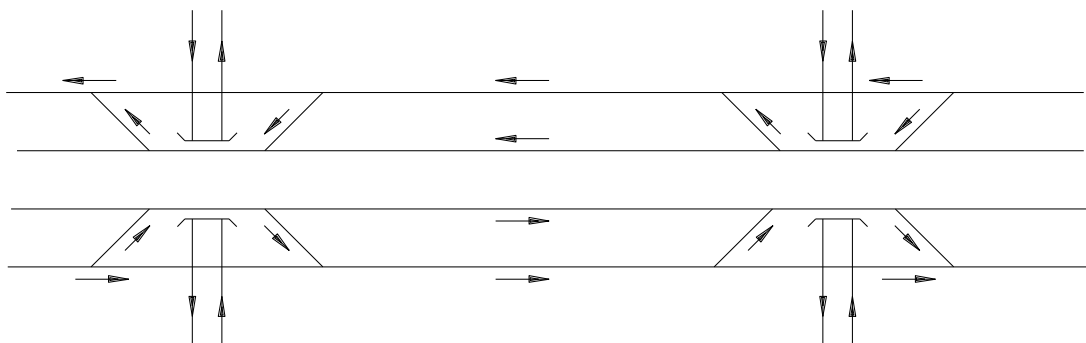

X - PATTERN RAMP ARRANGEMENT

FRONTAGE ROAD SCHEMATICS
Figure 6-4.02B

2. When there is a series of cross roads with a need for a number of on- and off-ramps along such a corridor, it may be beneficial to consider the use of 'X' pattern ramps at diamond interchanges, see Figure 6-4.02B. With this type of ramp pattern, the entrance occurs prior to the intersection, while the exit occurs after the cross street. This configuration can improve traffic flow characteristics for the through roadways around diamond interchanges. The only drawback is that the driver expectancy may be altered slightly in comparison to a conventional diamond configuration.
3. The merge and diverge designs for the ramp and the frontage road will be according to Figure 6-4.02C.

Table 6-4.02A
DISTANCE "A" FROM RAMP/FRONTAGE ROAD TO INTERSECTION WITH MINOR ROAD

Frontage Road Volume (VPH) ¹	Exit Ramp Volume (VPH) ²	"A" (ft)		
		Desirable	Minimum	Absolute Minimum
200	140	500	380	260
400	275	560	460	360
600	410	630	500	400
800	550	690	540	430
1,000	690	760	590	450
1,200	830	870	640	480
1,400	960	970	690	500
1,600	1,100	1,070	770	530
1,800	1,240	1,180	860	550
2,000	1,380	1,300	970	580

Distance A is shown on Figure 6-4.02B.

- 1) Total frontage road and exit ramp volume between merge to intersection with minor road.
- 2) Assumed to be 69 percent of total volume in first column.

REFERENCE:

"Frontage Road Ramp To Cross-street Distance Requirements In Urban Freeway Design," J. Michael Turner and Carroll J. Messer, Texas Transportation Institute, January 1978.

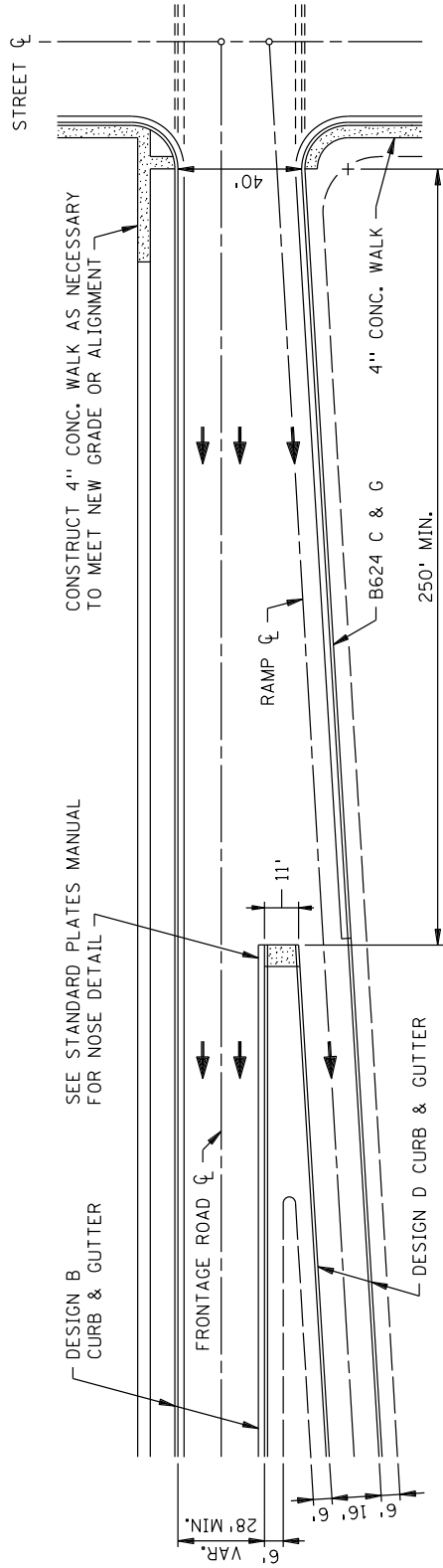

DIVERGING OF RAMP AND FRONTAGE ROAD

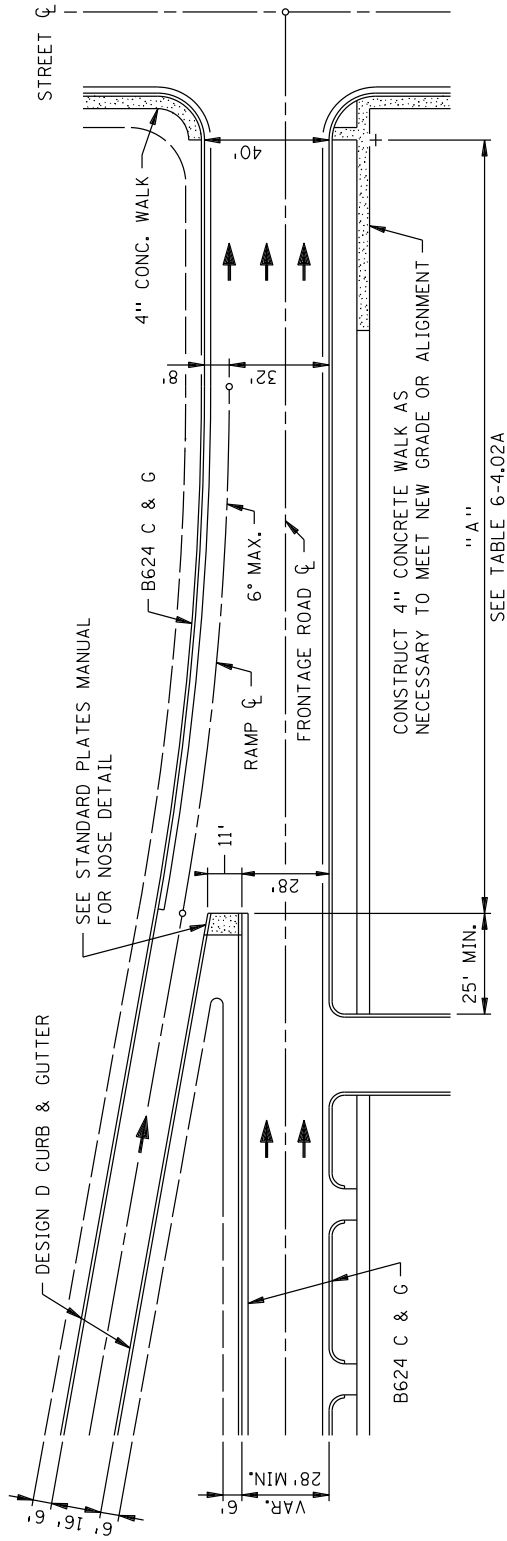

MERGING OF RAMP AND FRONTAGE ROAD

RAMP AND FRONTAGE ROAD ARRANGEMENTS
Figure 6-4.02C

6-5.0 COLLECTOR-DISTRIBUTOR (C-D) ROADS**6-5.01 General**

There are several advantages to constructing C-D roads:

1. Removing weaving from the mainline.
2. Providing adequate decision sight distance for all exiting traffic.
3. Providing one high-speed exit from the mainline for all exiting traffic.
4. Simplifying signing and decision-making.
5. Satisfying driver expectancy by placing exits in advance of the structure.

On the other hand, C-D roads increase cost due to the added roadway and bridge lengths. C-D roads may be provided within a single interchange, through two adjacent interchanges, or continuously through several interchanges of a freeway segment. They are warranted when traffic volumes are so high that, without them, the interchange cannot operate at an acceptable LOS. C-D roads are particularly advantageous when constructed to eliminate weaving at a cloverleaf interchange with loops in adjacent quadrants.

C-D roads may be one or two lanes, depending on the traffic volumes and weaving conditions. Lane balance should be maintained at the exit and entrance points of the C-D road. The design speed of C-D roads should desirably be the same as the mainline. 15 mph should be the maximum difference between the two design speeds. The separation between the C-D road and the mainline should be as wide as practicable, and not less than the distance required to provide the proper shoulder widths and a barrier. The pavement type of the C-D road should be the same as that of the mainline.

At some directional interchanges it may be beneficial to provide two separate exits (instead of one exit with a C-D road). Those are the directional interchanges where the distance from the exit terminal to the bifurcation of the two ramps is insufficient for weaving and proper signing. The situation is exacerbated at directional interchanges with volumes large enough to warrant a two-lane exit. Such cases often lead to confusion at the second decision point resulting in poor operation and high accident potential. In these cases it is better to provide two separate exits.

6-6.0 Major Forks (Diverges)

6-6.01 Application

Major forks are the divergence of:

1. Mainline and C-D road;
2. A terminating freeway and two multi-lane directional ramps; or
3. A freeway separating into two freeways.

6-6.02 Design of Major Forks

The design of major forks requires that the principles of freeway design – basic number of lanes, auxiliary lanes, route continuity, and lane balance – be thoroughly examined. To adequately examine these principles for major forks, the designer must include a broader review of the freeway system. The broader review should consider the freeways approaching and departing the major fork for at least one mile, and possibly longer depending on the circumstances.

A traffic study should be conducted on any major fork design or redesign, where traffic volumes are high and/or interchange spacing is less than one-mile. The dynamic nature of major fork areas in these situations makes them difficult to understand and make the optimal design decisions with a less detailed analysis.

The design of major forks depends on the number of basic freeway lanes that exist prior to the divergence. A design exception is required for designs that deviate from the guidelines for major forks found in AASHTO's *A Policy on Geometric Design of Highways and Streets*.

6-6.02.01 Major Forks on Freeways with 2 or 3 Basic Lanes Prior to the Diverge

The design of major forks should comply with Lane Balance principles. If there is adequate approaching capacity and the total number of departing lanes is equal to approaching plus one, then operational flexibility will be obtained. Other factors to consider in designing major forks on freeways with 2 or 3 basic lanes prior to the divergence: interchange spacing, total traffic volumes, and weaving volumes.

Table 6-6.02A presents a design guideline for major forks based on traffic and interchange spacing. Figure 6-6.02A is a schematic of major forks lane configuration for freeways with 3 lanes prior to the divergence. The preferred designs are Type 1 and Type 2 major forks as seen in Figure 6-6.02A. A detail design of a Type 1 major fork is shown in figure 6-6.02B.

Consideration can be given to Type 3 major forks if the minimum spacing between the major fork and the nearest upstream entrance ramp is 3,300 feet or greater, and the right leg departing volume is less than 4,000 passenger cars per hour (pcph) during the peak design hour. The likely reason for considering this design is if the upstream entrance ramp experiences traffic volumes over 1,000 pcph during the peak period, this high of a volume may require a long auxiliary lane for merging traffic. The full auxiliary lane, if extended through the major fork, in this case violates lane balance principles, however, the trade off of lowering the density in the weave area may outweigh the loss of lane balance. Type 3 major forks will require an exception to AASHTO's *A Policy on Geometric Design of Highways and Streets*.

As traffic volumes meet and exceed the volume thresholds in Table 6-6.02A, the need for more basic lanes or auxiliary lanes will occur. When more lanes are incorporated into the design the following section should be used.

6-6.02.02 Major Forks on Freeways with 4 or 5 Basic Lanes Prior to the Diverge

The importance of maintaining lane balance at major forks increases where a higher number of basic freeway lanes are present prior to the divergence. This is due to the likely fluctuations of traffic between the two departing legs, and the number of lane changes to move between the departing legs. The fluctuations between traffic volumes and additional lane changing requirements force the need for more flexibility. In order to make the proper decisions, a traffic study and analysis has to be prepared to verify the appropriate configuration.

**Table 6-6.02A
MAJOR FORK DESIGN GUIDELINE MATRIX**

Number of Basic Freeway Lanes prior to Diverge	Upstream Interchange Spacing	Design Year Peak Hour Traffic			Design Layout (See Figure 6-6.02A for schematic)
		Total Volume Prior to Diverge	Upstream entrance-ramp volume	Maximum volume of either leg	
2	2,500 ft or less	At Least 3 Lanes are required a minimum distance of 1/2 mile upstream of a Major Fork Diverge 2 lanes going into 2 + 2 unacceptable See Criteria for 3 basic lanes			
	2,500 ft - 3,000 ft				
	Over 3,000 feet				
3	2,500 ft or less	Traffic Study Required	Traffic Study Required	Traffic Study Required	Traffic Study Required
	2,500 ft - 3,000 ft	≤5,000 pcph	≤1,000 pcph	≤4,000 pcph	2
		≤5,400 pcph	≤1,800 pcph	≤4,000 pcph	3
	Over 3,000 feet	≤5,400 pcph	≤1,000 pcph	≤4,000 pcph	1
>5,400 pcph		N/a	More Lanes Required	More Lanes Required	
4	2,500 ft or less	Traffic Study Required: Freeways with 4 basic lanes are within Metro Area and typically experience severe congestion			
	2,500 ft - 3,000 ft				
	Over 3,000 feet				

pcph = passenger cars per hour

6-6.02.03 Lane Drop Guidelines at Major Forks

Based on observations in the Twin Cities Metropolitan Area, lane drops located just beyond a major fork have a negative impact on operations. Therefore, the minimum distance for a freeway lane to be dropped beyond a major fork is one-mile. That minimum distance is necessary for properly incorporating a lane drop warning sign that will not affect operations within the gore area of the major fork. The schematic in Figure 6-6.02C illustrates this requirement.

The one-mile distance of the lane drop should be lengthened if the following conditions are included within the one-mile distance:

- Vertical or Horizontal Geometric obstructions
- Other Sight obstructions
- Exit-ramps

Figure 6-6.02D illustrates the required modifications to the lane drop distance if an exit-ramp occurs within the one-mile distance. The influence of signing for vehicles exiting at the ramp beyond the major fork will displace the warning sign for the lane drop by the length of the exit ramp location. The minimum spacing distance for an exit-ramp followed by an exit-ramp is 1,000 feet.

Figure 6-6.02E illustrates a major fork followed by an entrance ramp. An entrance ramp has less of an impact on operations than an exit ramp with respect to the divergence of the major fork because there are no signs for an entrance ramp required at the major fork. Based on the minimal impact the lane drop need not be extended to accommodate the signing. The minimum spacing distance for an exit-ramp followed by an entrance-ramp is 500 feet.

If extreme constraints exist, the ability to maintain lane balance and a one-mile distance prior to a lane-drop is not possible, then consideration should be given to not maintaining lane balance. Under this circumstance, a traffic study must be conducted to determine if the design year condition for both morning and afternoon commute periods will operate and will require an exception to AASHTO's *A Policy on Geometric Design of Highways and Streets*.

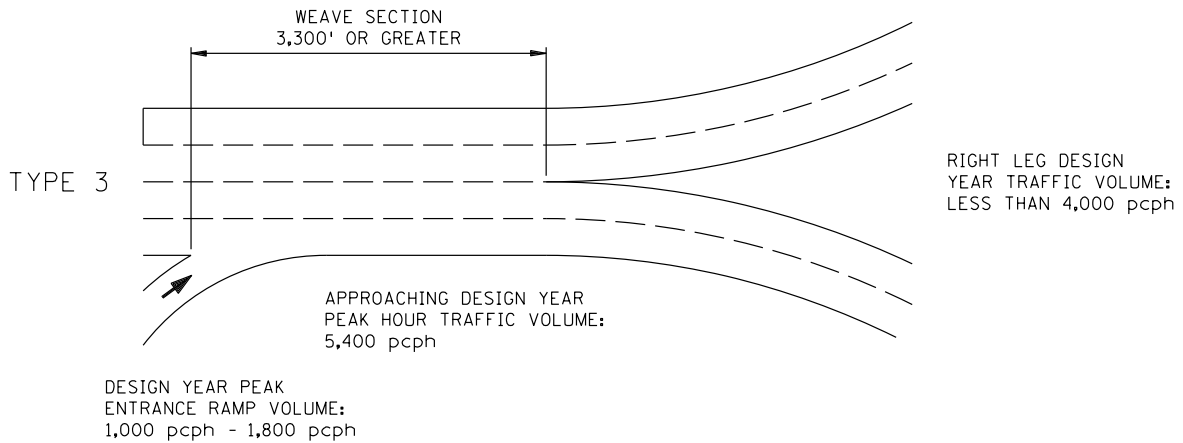
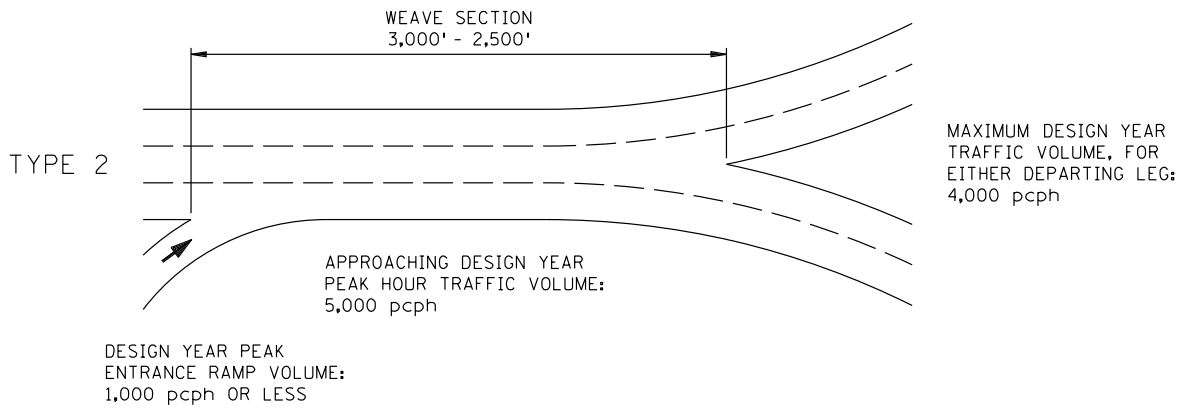
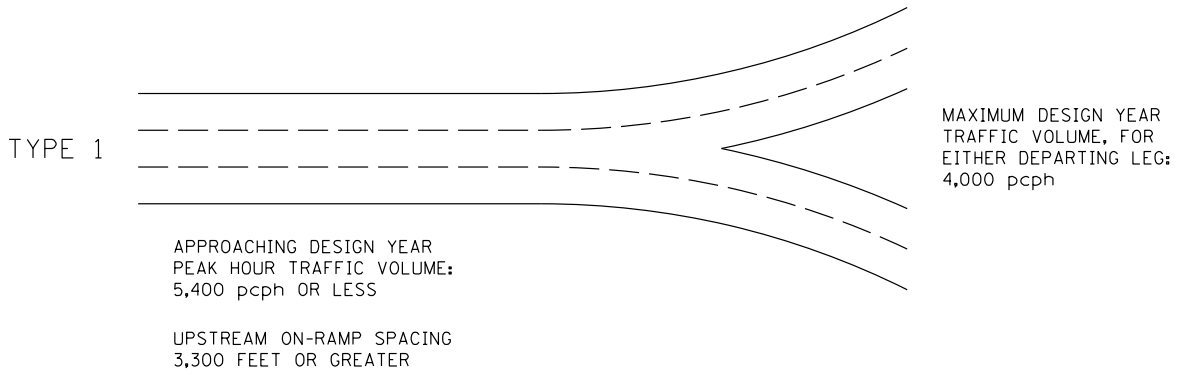

NOTE:
SEE TABLE 6-6.02A FOR A DESIGN GUIDELINE MATRIX.

**MAJOR FORK LANE CONFIGURATION
FOR THREE BASIC LANES PRIOR TO THE DIVERGE**
Figure 6-6.02A

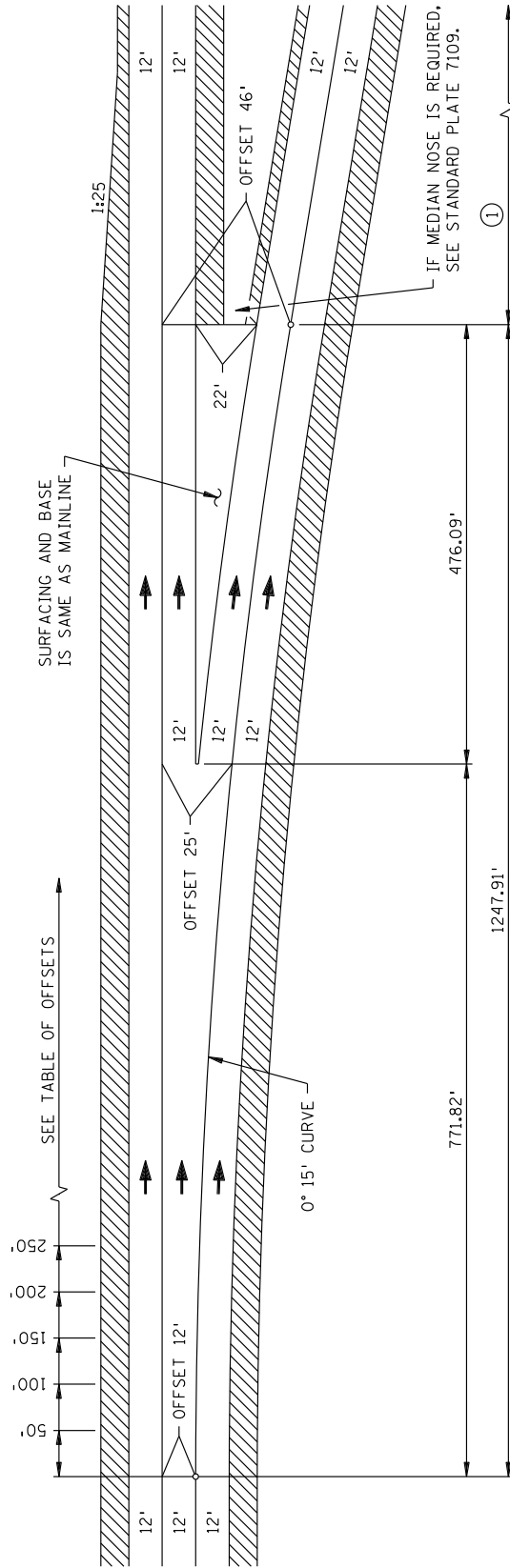

$\Delta = 3^\circ 07' 17''$
 $D = 0^\circ 15'$
 $T = 624.42'$
 $L = 1248.53'$

TABLE OF OFFSETS (0° 15' CURVE)

DISTANCE (FT)	0	50	100	150	200	250	300	350	400
OFFSET (FT)	12.00	12.04	12.22	12.49	12.88	13.36	13.96	14.68	15.49
DISTANCE (FT)	450	500	550	600	650	700	750	800	850
OFFSET (FT)	16.42	17.45	18.60	19.86	21.22	22.69	24.27	25.97	27.77
DISTANCE (FT)	900	950	1000	1050	1100	1150	1200	1247.91	
OFFSET (FT)	29.68	31.70	33.83	36.06	38.41	40.87	43.44	46.00	

NOTES:
 WHERE THE ROADWAY IS ON TANGENT, THE RATE OF DIVERGENCE IS A 0° 15' CURVE.

WHEN THE ROADWAY IS ON A CURVE, THE RATE OF DIVERGENCE SHOULD REMAIN THE SAME BY USING THE TABLE OF OFFSETS.

① THE MINIMUM DESIGN APPROACHING THE EXIT NOSE SHOULD PROVIDE 10 SECONDS OF APPROACH SIGHT FOR THE VEHICLE OPERATOR. THE SIGHT DISTANCE BEYOND THE EXIT NOSE FOR BOTH ROADWAYS SHALL BE GREATER THAN THE STOPPING SIGHT DISTANCE. SEE SECTION 2-5.09 FOR A DETAILED DISCUSSION.

MAJOR FORKS
Figure 6-6.02B

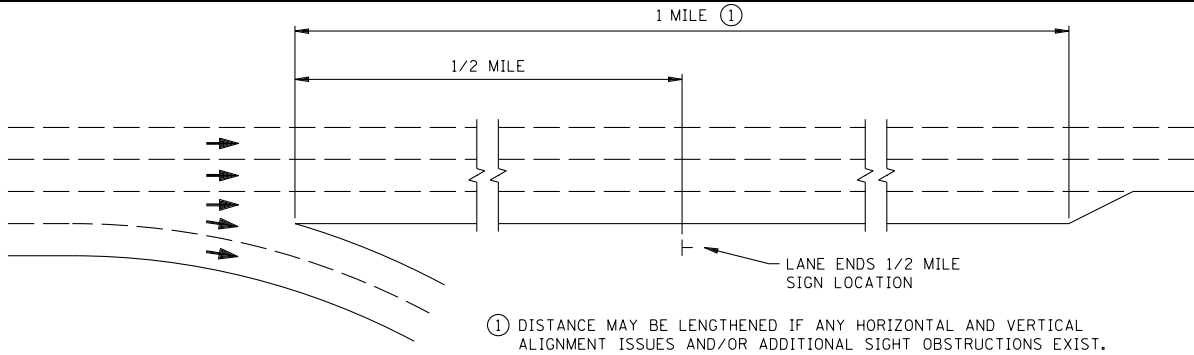

LANE DROP REQUIREMENT BEYOND MAJOR FORK DIVERGE
Figure 6-6.02C

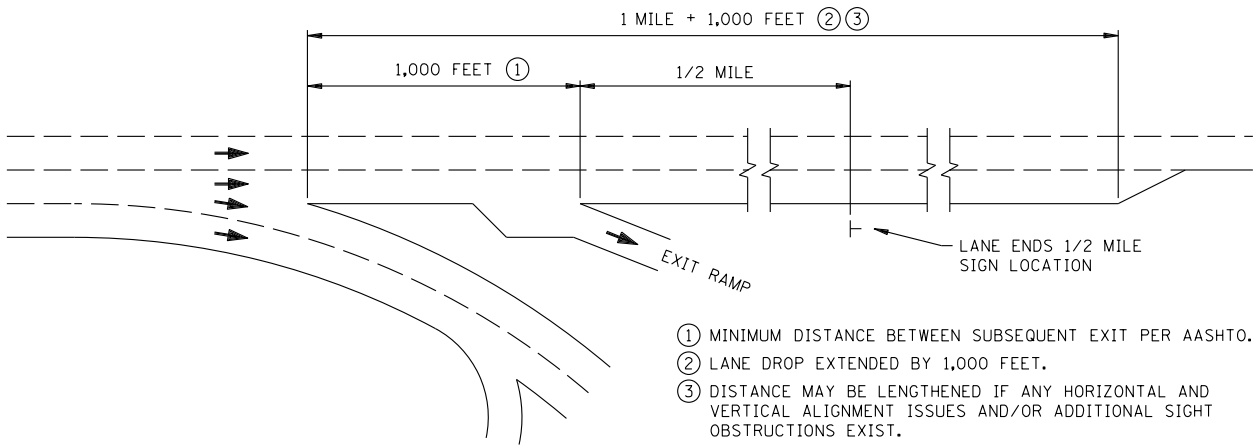

MINIMUM LANE DROP DISTANCE BEYOND MAJOR FORK DIVERGE WITH DOWNSTREAM EXIT RAMP IN BETWEEN
Figure 6-6.02D

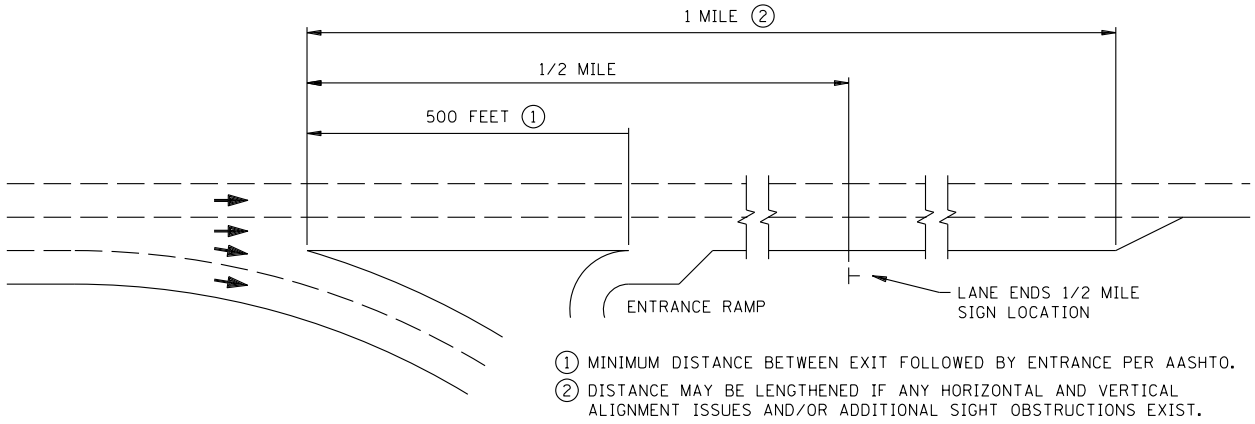

LANE DROP DISTANCE BEYOND MAJOR FORK DIVERGE DOWNSREAM WITH ENTRANCE RAMP IN BETWEEN
Figure 6-6.02E

6-7.0 Branch Connections (Merges)**6-7.01 Application**

Branch Connections are the convergence of:

1. Mainline and C-D road;
2. Two directional multi-lane ramps;
3. Two freeways forming a single freeway; or
4. Freeway and multi-lane ramps.

Figure 6-7.01A shows the design details of a branch connection. The design must comply with the principle of lane balance to minimize operational problems and driver confusion. The branch connection design shows 1,300 ft as the minimum distance to be provided before dropping a lane. Greater distances may be needed based on an assessment of the need to sign the lane drop, projected traffic volumes in the dropped and through lanes, sight distances, and the horizontal and vertical alignment.

If the traffic volume exceeds the capacity of the existing freeway lanes, another lane should be added. As an alternative, the design could allow the inside lane of the minor volume route to merge into the adjacent lane of the major route. This merge should be accomplished in a gradual design that would approximate a 1:70 taper. This design should be selected only if a freeway analysis demonstrates that it will result in better traffic operation.

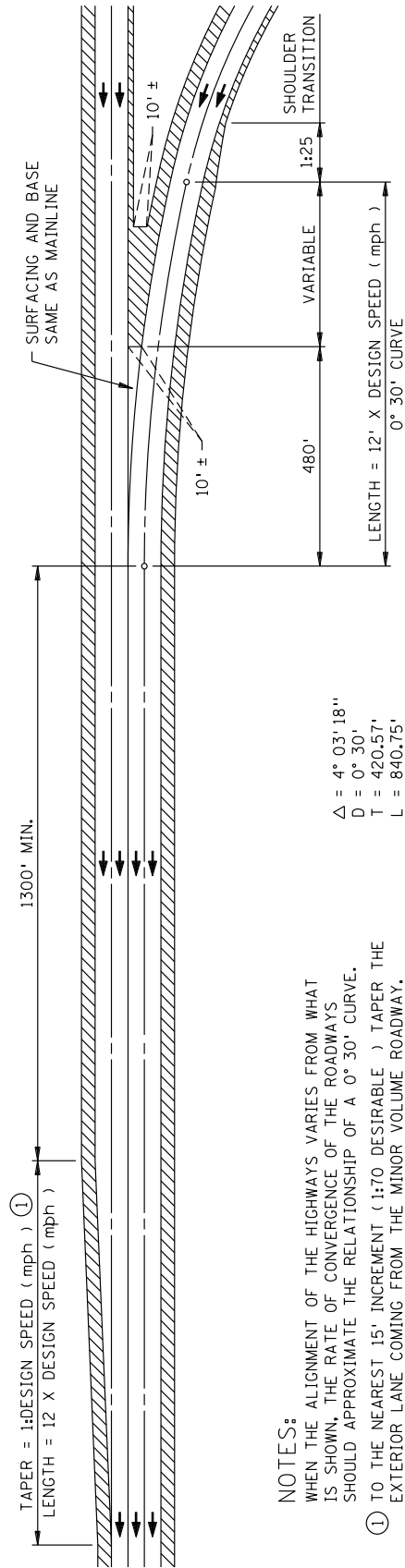

NOTES:
 WHEN THE ALIGNMENT OF THE HIGHWAYS VARIES FROM WHAT IS SHOWN, THE RATE OF CONVERGENCE OF THE ROADWAYS SHOULD APPROXIMATE THE RELATIONSHIP OF A 0° 30' CURVE.
 ① TO THE NEAREST 15' INCREMENT (1:70 DESIRABLE) TAPER THE EXTERIOR LANE COMING FROM THE MINOR VOLUME ROADWAY.

TABLE OF OFFSETS (0° 30' CURVE)

DESIGN SPEED (mph)	10' PHYSICAL NOSE										10' GORE NOSE											
	0	50	100	150	200	250	300	350	400	450	480	480	500	550	600	650	700	740	750	800	840	
DISTANCE (FT)	0	50	100	150	200	250	300	350	400	450	480	480	500	550	600	650	700	740	750	800	840	
OFFSET (FT)	24.00	24.11	24.44	24.98	25.75	26.73	27.93	29.35	30.98	32.84	34.06	34.06	34.91	37.21	39.72	42.45	45.40	47.92	48.57	51.96	54.83	
DESIGN SPEED (mph)											40											60

BRANCH CONNECTIONS

Figure 6-7.02A