

PLOTTED/REVISED: 1/2/2013

DISTRICT #: METRO
IPLOT NAME: T20584A_SGLI
PATH & FILENAME: IP_PWP-d1484053VT20584A_SGL.dgn

DETECTOR CHART			
NUMBER	SIZE (FT)	LOCATION	STATUS
V1-1	2-6 X 6	35'	F & I
V1-2	2-6 X 6	5'	F & I
D2-1, D2-2	6 X 6	180'	F & I
D4-1, D4-2	6 X 6	120'	INPLACE
D4-3, D4-4	2-6 X 6	5' & 20'	INPLACE
D4-5	6 X 6	5'	INPLACE
V6-1, V6-2	6 X 6	230'	F & I

-ALL LOOP DETECTORS SHALL BE PVC UNLESS NOTED OTHERWISE
-LOCATION: DISTANCE FROM CROSSWALK/STOP BAR IN FEET
-ITEMS DENOTED WITH A "V" INDICATES VIDEO DETECTION

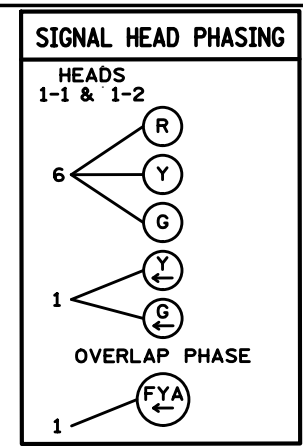

5 SECTION FYA BI-MODAL HEAD DETAIL

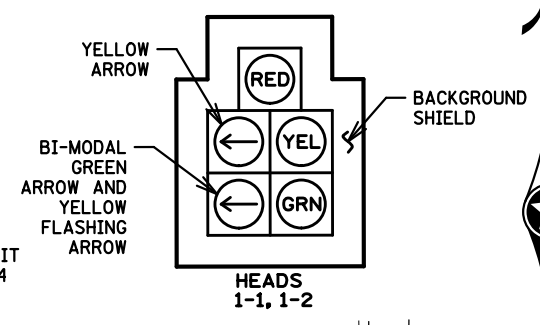

SIGNAL FACE CHART						
FACE	R	Y	FYA	G	Y	G
1-1, 1-2	●	●	←	●	←	←
2-1, 2-2	●	●		●		
4-1, 4-2, 4-3	●	●		●		
6-1, 6-2	●	●		●		

-ALL SIGNAL INDICATIONS SHALL BE 12" LED
-ALL SIGNAL HEADS SHALL BE BLACK POLYCARBONITE WITH BACKGROUND SHIELDS
-FYA DENOTES FLASHING YELLOW ARROW

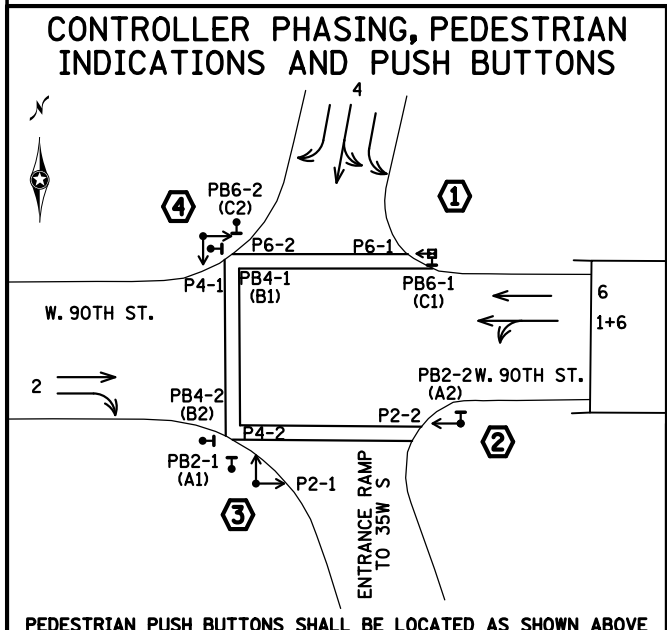
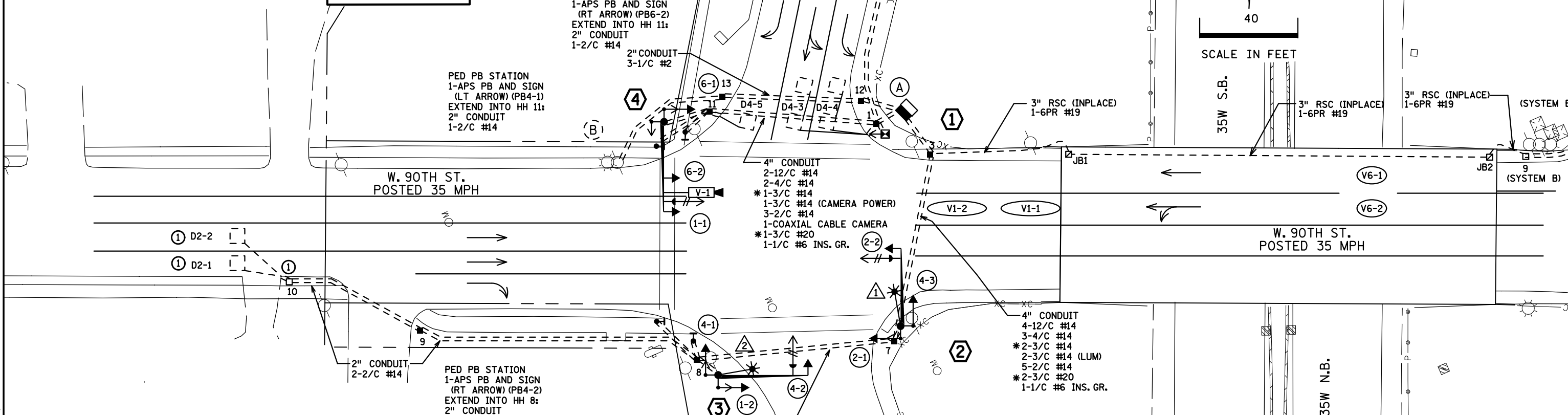
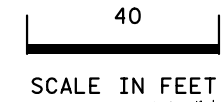

NOTE:
THIS PLAN SPECIFIES COAXIAL (VIDEO) AND 3/C #14 (POWER) CABLES FOR THE VIDEO DETECTION CAMERAS. THE ACTUAL CABLE OR CABLES REQUIRED DEPEND ON THE TYPE OF VIDEO DETECTION SYSTEM SUPPLIED.

SIGNAL SYSTEM OPERATION

- THE SIGNAL SYSTEM FLASH MODE IS ALL RED.
- NORMAL OPERATION IS 4 PHASE, WITH PHASE 1 BEING FLASHING YELLOW ARROWS BY TIME OF DAY.
- PHASES 2 AND 6 SHALL BE ON VEHICLE RECALL.

① THE LOOP DETECTORS AND ADJACENT HANDHOLE WILL BE CONSTRUCTED WITH A CITY OF BLOOMINGTON PAVEMENT REPLACEMENT PROJECT (S.A.P. 107-130-043). THE CITY PROJECT IS SCHEDULED JUST PRIOR TO THIS PROJECT.

- NOTES:
- SEE SPECIAL PROVISIONS FOR STATE FURNISHED MATERIALS.
 - REFER TO "FOR INFORMATION ONLY" SHEETS FOR INPLACE SIGNAL COMPONENTS.
 - THE EXACT LOCATION OF HANDHOLES, POLES, LOOP DETECTORS AND EQUIPMENT PAD, SHALL BE VERIFIED IN THE FIELD BY MNDOT TRAFFIC OFFICE PERSONNEL.
 - THE CONTRACTOR IS RESPONSIBLE FOR COORDINATING THE CONNECTION OF THE POWER FOR THE TRAFFIC SIGNAL SYSTEM.
 - FOR REQUIRED MAST ARM SIGNS, SEE THE MAST ARM SIGNING LAYOUT SHEET FOR SIGNING INFORMATION. ALL SIGNING WORK IS INCLUDED IN PAYMENT FOR THE LUMP SUM SIGNAL SYSTEM PAY ITEM.
 - CROSSWALK PAVEMENT MARKINGS ARE PAID FOR AND INCLUDED WITH THE STRIPING PLAN.
 - CONSTRUCTION OF PEDESTRIAN CURB RAMPS AND CONCRETE WALK ARE PAID FOR AND INCLUDED WITH THE ROADWAY PLAN.
 - THIS PLAN SPECIFIES CONDUIT SIZES, TYPES, AND GENERAL LOCATIONS. THE EXACT LOCATIONS WILL BE DETERMINED IN THE FIELD. CONDUITS UNDER THE ROADWAYS REQUIRE BORING.
 - ALL NEW CONDUIT SHALL BE PVC - SCHEDULE 80 OR HDPE SCHEDULE 80 AND SHALL CARRY 1/C#6 GREEN INSULATED GROUNDING CONDUCTOR AS SHOWN IN THE PLAN.
 - ITEMS DENOTED WITH AN * ARE INCLUDED IN PAYMENT FOR THE EVP SYSTEM PAY ITEM.
 - THE CHAINLINK FENCE NEAR THE SIGNAL CABINET WILL BE REMOVED AND REPLACED AS PART OF THE ROADWAY PLAN.

BY	DATE	REVISIONS	SYSTEM ID: 20584	T.E. 5701	INTERSECTION LAYOUT TRAFFIC CONTROL SIGNAL SYSTEM "A" T.H. 35W WEST RAMP AT W 90TH ST. IN BLOOMINGTON, HENNEPIN COUNTY	S.A.P. NO. 107-130-043	DRAWN BY: BAM	CKD BY: CDB	DATE: 12/13/12	
			METER ADDRESS:			CERTIFIED BY: <i>Michael P. Gubinsky</i>	LIC. NO. 19863	DATE: 12/13/12		
			MASTER ID:	T.E.		STATE PROJ. NO. 2782-321 (T.H. 35W) SHEET NO. SS7 OF SS23 SHEETS				

PLOTTED/REVISED: 1/2/2013

- ④ PA90 POLE FOUNDATION
TYPE PA90-A-35
- ① (A 3/4" THREADED HALF COUPLING (FOR EVP MOUNTING), SHALL BE F&I 4' FROM THE END OF THE MAST ARM)
- 1-ANGLE MOUNT SIGNAL OVERHEAD AT 0'
- 1-STRAIGHT MOUNT SIGNAL OVERHEAD AT 11'
- 1-ANGLE MOUNT SIGNAL AT 180 DEG
- 2-ANGLE MOUNT C.D. PED IND AT 90 AND 180 DEG
- * 1-ONE WAY EVP DETECTOR AND CONFIRMATORY LIGHT (PHASES 6+1)
- 1-VIDEO CAMERA MOUNTED ON 6' EXTENSION ON MAST ARM AT 2'
- 1-R10-X12 SIGN ADJACENT TO HEAD (1-1)
- 2-TYPE D SIGN D-1 & D-4
- 3" CONDUIT TO HH 11:
- 2-12/C #14
- 2-4/C #14
- * 1-3/C #14
- 1-3/C #14 (CAMERA POWER)
- 1-COAXIAL CABLE CAMERA
- * 1-3/C #20
- 1-1/C #6 INS. GR.

- ① PEDESTAL FOUNDATION
TYPE 4A
- 10' PEDESTAL POLE AND BASE (9' POLE PLUS BASE)
- 1-C.D. PED IND
- 1-APS PB AND SIGN (LT ARROW) (PB6-1)
- 2-ONE WAY SIGNS (R6-1) (SALVAGE AND INSTALL)
- 3" CONDUIT TO HH 3:
- 1-4/C #14
- 1-2/C #14
- 1-1/C #6 INS. GR.

- Ⓐ EQUIPMENT PAD (SEE DETAIL SHEET)
- SERVICE CABINET (SSB)
- CONTROLLER AND CABINET (STATE FURNISHED)
- 4" CONDUIT TO HH 1: 4" CONDUIT TO HH 3:
- 2-12/C #14 4-12/C #14
- 3-4/C #14 3-4/C #14
- * 1-3/C #14 * 2-3/C #14
- 1-3/C #14 (CAMERA POWER) 5-2/C #14
- 8-2/C #14 * 2-3/C #20
- 1-COAXIAL CABLE CAMERA 1-6PR #19
- * 1-3/C #20 1-1/C #6 INS. GR.
- 1-1/C #6 INS. GR.

① MAST ARMS FOR POLES NO. 2 & NO. 4 HAVE NON-STANDARD EVP MOUNTING LOCATIONS DUE TO CONFLICTS WITH MAST ARM SIGNING.

NOTE:
1. ITEMS DENOTED WITH AN * ARE INCLUDED IN PAYMENT FOR THE EVP SYSTEM PAY ITEM.

1-2" AND 1-3" CONDUIT STUBBED OUT (CAPPED BOTH ENDS)
3/4" CONDUIT STUBBED OUT (FOR TELEPHONE LINE)

CONTROLLER CABINET TO SERVICE CABINET:
2" CONDUIT
2-1/C #6
1-1/C #6 INS. GR.

CONTROLLER CABINET TO SERVICE CABINET (COMMS):
2" CONDUIT
1-6PR #19

SERVICE CABINET TO POLE MOUNTED TRANSFORMER:
2" CONDUIT
3-1/C #2

SERVICE CABINET TO HH 3:
2" CONDUIT
2-3/C #14 (LUM)

SERVICE CABINET TO HH 12 TO HH 13 TO SOP:
2" CONDUIT
3-1/C #2

- ③ PA90 POLE FOUNDATION
TYPE PA90-A-35-D40-9 (DAVIT AT 350 DEG)
- 1-ANGLE MOUNT SIGNAL OVERHEAD AT 0'
- 2-ANGLE MOUNT SIGNALS AT 90 AND 180 DEG
- 2-ANGLE MOUNT C.D. PED IND AT 90 AND 180 DEG
- * 1-ONE WAY EVP DETECTOR AND CONFIRMATORY LIGHT (PHASE 4)
- LUMINAIRE-250W HPS
- 2-ONE WAY SIGNS (R6-1) (SALVAGE AND INSTALL)
- 1-TYPE D SIGN (SALVAGE AND INSTALL)
- 3" CONDUIT TO HH 8:
- 2-12/C #14
- 2-4/C #14
- * 1-3/C #14
- 1-3/C #14 (LUM)
- * 1-3/C #20
- 1-1/C #6 INS. GR.

- ② PA90 POLE FOUNDATION
TYPE PA90-A-30-D40-9 (DAVIT AT 350 DEG)
- ① (A 3/4" THREADED HALF COUPLING (FOR EVP MOUNTING), SHALL BE F&I 10' FROM THE END OF THE MAST ARM)
- 1-ANGLE MOUNT SIGNAL OVERHEAD AT 0'
- 2-ANGLE MOUNT SIGNALS AT 90 AND 180 DEG
- 1-ANGLE MOUNT C.D. PED IND AT 180 DEG
- * 1-ONE WAY EVP DETECTOR AND CONFIRMATORY LIGHT (PHASES 2)
- LUMINAIRE-250W HPS
- 1-APS PB AND SIGN (RT ARROW) (PB2-2)
- 2-TYPE D SIGN D-2 & D-3
- 3" CONDUIT TO HH 7:
- 2-12/C #14
- 1-4/C #14
- * 1-3/C #14
- 1-3/C #14 (LUM)
- 1-2/C #14
- * 1-3/C #20
- 1-1/C #6 INS. GR.

- Ⓑ INPLACE SOP
- WOOD POLE
- EXTEND INTO HH 13:
- 2" CONDUIT AND WEATHERHEAD
- WITH 3-1/C #2

DISTRICT #: METRO
PLOT NAME: notes west ramp
PATH & FILENAME: IP_PWP-d1484053V20584A_SGL.dgn

BY	DATE	REVISIONS	SYSTEM ID: 20584	T.E. 5701	INTERSECTION LAYOUT POLE NOTES TRAFFIC CONTROL SIGNAL SYSTEM "A" T.H. 35W WEST RAMP AT W 90TH ST. IN BLOOMINGTON, HENNEPIN COUNTY	S.A.P. NO. 107-130-043	DRAWN BY: BAM	CKD BY: CDB	DATE: 12/13/12
			METER ADDRESS:			CERTIFIED BY <i>Michael P. Dubinsky</i>	LIC. NO. 19863	DATE: 12/13/12	
			MASTER ID:	T.E.		STATE PROJ. NO. 2782-321 (T.H. 35W)		SHEET NO. SS8 OF SS23 SHEETS	

PLOTTED/REVISED: 1/21/2013

DISTRICT #: METRO
PLOT NAME: T20584WIRE
PATH & FILENAME: IP_PWP-d1484053V20584A_SGL.dgn

CONTROLLER CABINET

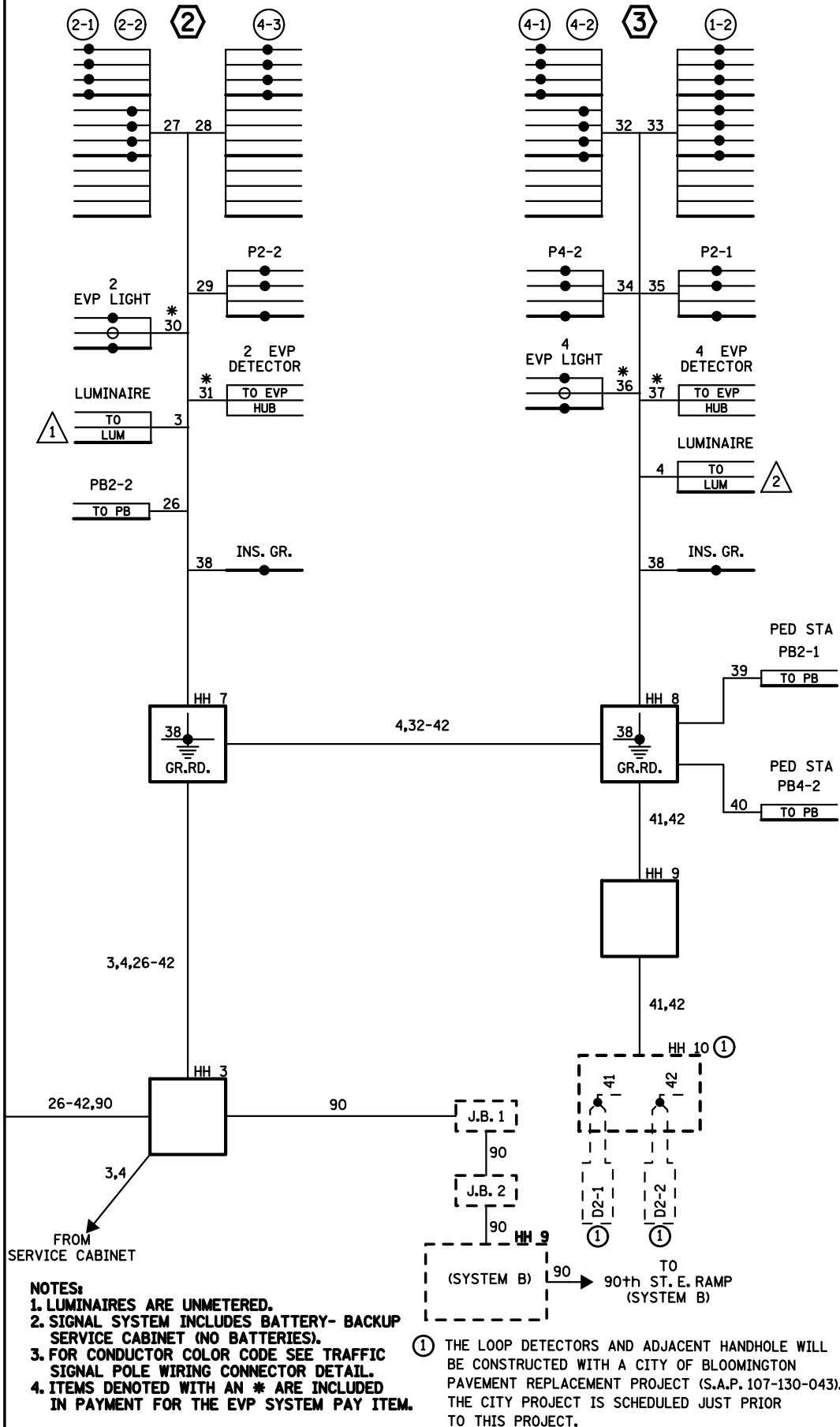
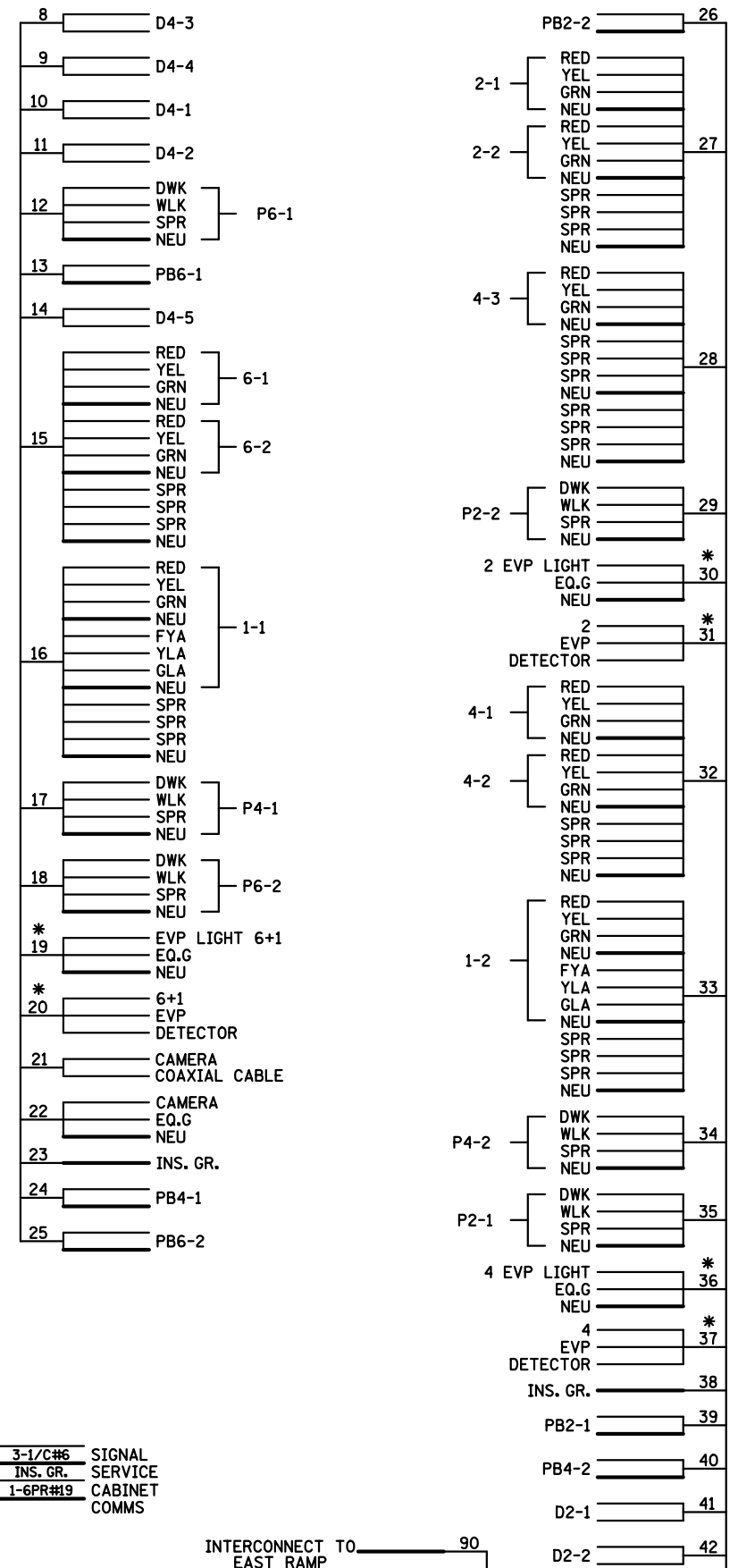
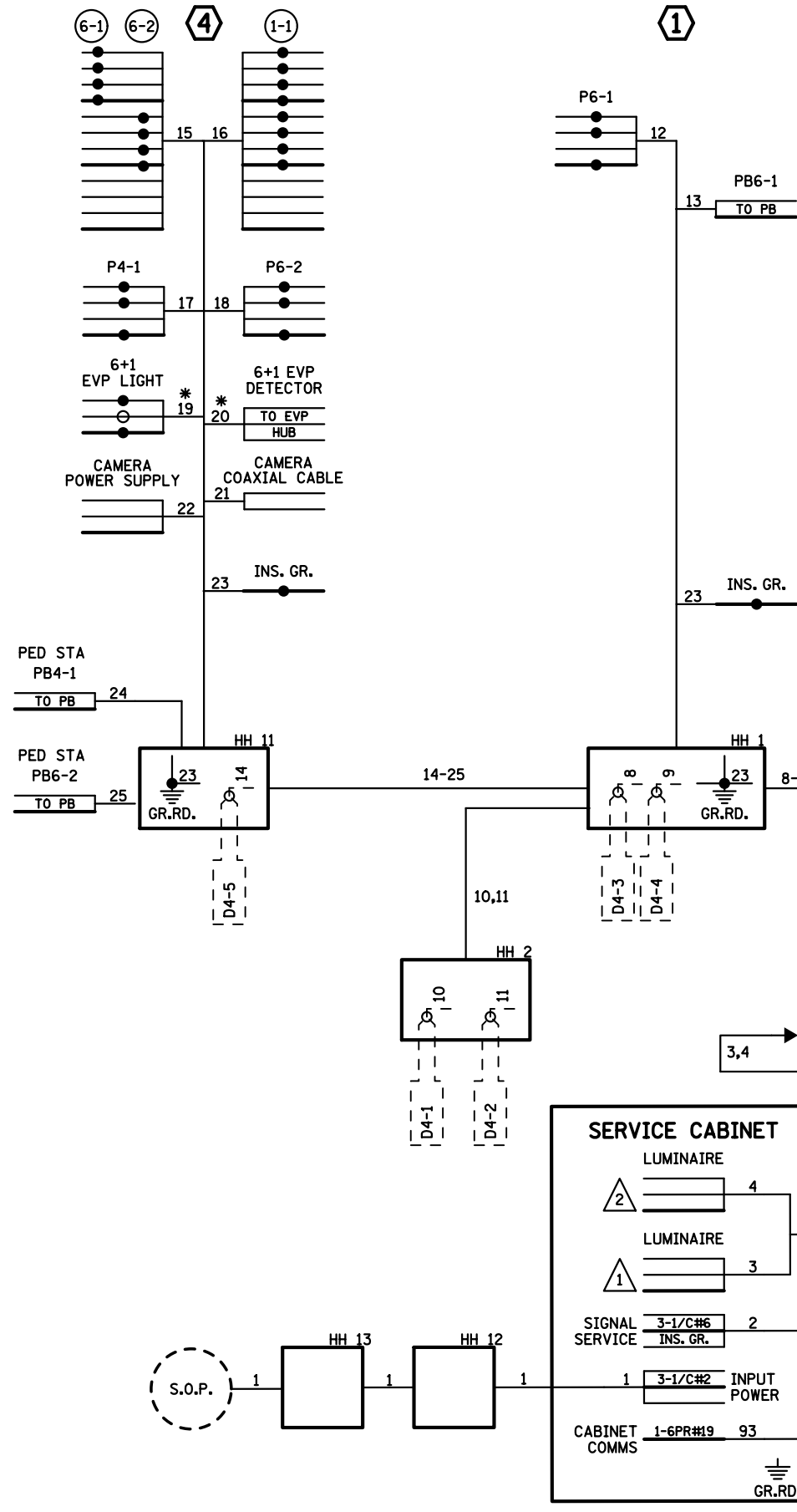

NOTES:
 1. LUMINAIRES ARE UNMETERED.
 2. SIGNAL SYSTEM INCLUDES BATTERY- BACKUP SERVICE CABINET (NO BATTERIES).
 3. FOR CONDUCTOR COLOR CODE SEE TRAFFIC SIGNAL POLE WIRING CONNECTOR DETAIL.
 4. ITEMS DENOTED WITH AN * ARE INCLUDED IN PAYMENT FOR THE EVP SYSTEM PAY ITEM.

① THE LOOP DETECTORS AND ADJACENT HANDHOLE WILL BE CONSTRUCTED WITH A CITY OF BLOOMINGTON PAVEMENT REPLACEMENT PROJECT (S.A.P. 107-130-043). THE CITY PROJECT IS SCHEDULED JUST PRIOR TO THIS PROJECT.

BY	DATE	REVISIONS

SYSTEM ID: 20584	T.E. 5701
METER ADDRESS:	
MASTER ID:	T.E.

**FIELD WIRING DIAGRAM
 TRAFFIC CONTROL SIGNAL SYSTEM "A"
 T.H. 35W WEST RAMP AT W 90TH ST.
 IN BLOOMINGTON, HENNEPIN COUNTY**

S.A.P. NO. 107-130-043	DRAWN BY: BAM	CKD BY: CDB	DATE: 12/13/12
CERTIFIED BY: <i>Michael P. Sabersky</i>	LIC. NO. 19863	DATE: 12/13/12	
STATE PROJ. NO. 2782-321 (T.H. 35W) SHEET NO. SS9 OF SS23 SHEETS			

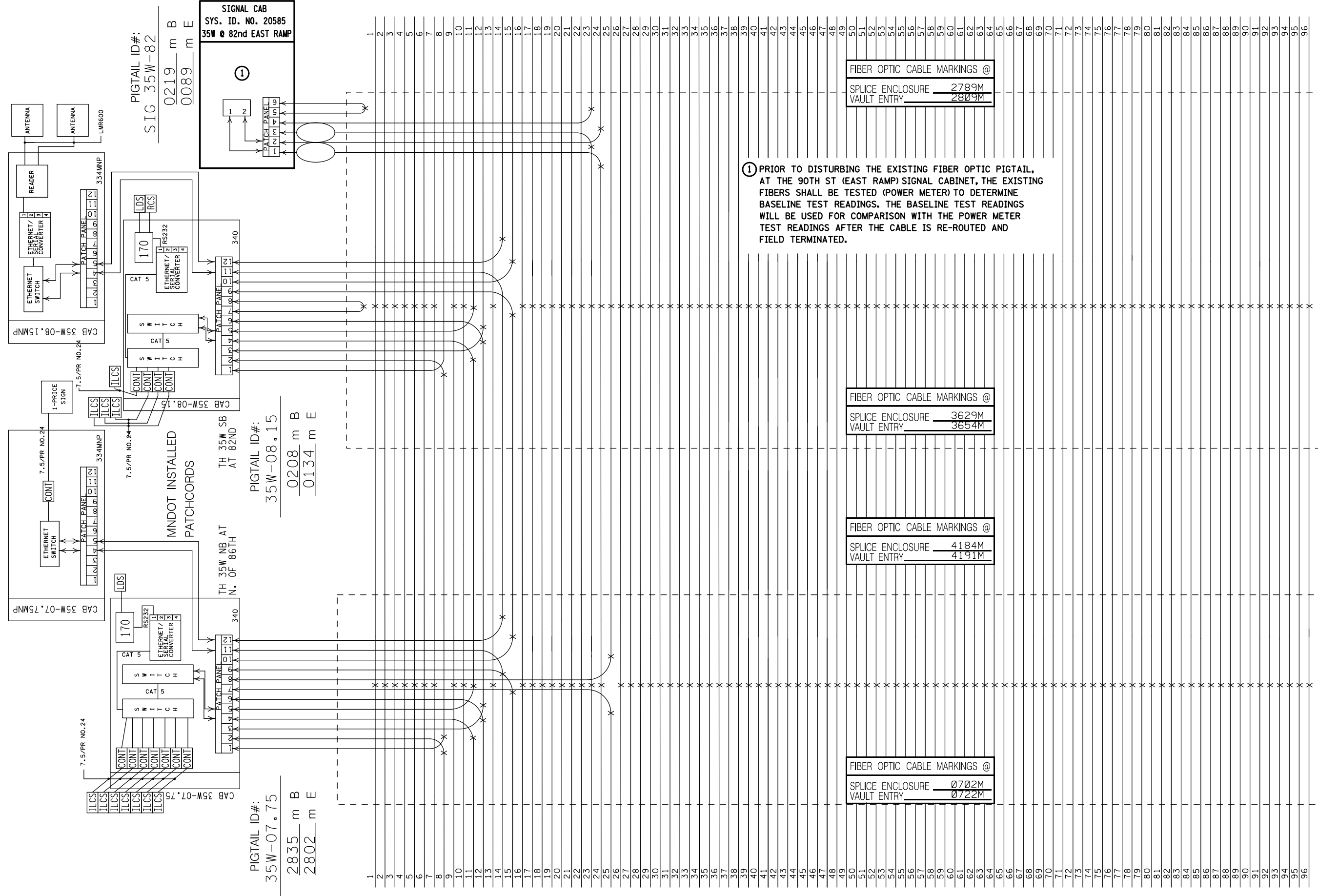

① PRIOR TO DISTURBING THE EXISTING FIBER OPTIC PIGTAIL, AT THE 90TH ST (EAST RAMP) SIGNAL CABINET, THE EXISTING FIBERS SHALL BE TESTED (POWER METER) TO DETERMINE BASELINE TEST READINGS. THE BASELINE TEST READINGS WILL BE USED FOR COMPARISON WITH THE POWER METER TEST READINGS AFTER THE CABLE IS RE-ROUTED AND FIELD TERMINATED.

F-35WU.56 VAULT @ N.OF 86TH (EAST) INDEX OF REFRACTION 1.467
 F-35WU.59 VAULT @ 82ND (EAST)
 F-35WU.62 VAULT @ 82ND (EAST)

PIGTAIL ID#:
 35W-07.75
 2835 m B
 2802 m E

PIGTAIL ID#:
 35W-08.15
 0208 m B
 0134 m E

PIGTAIL ID#:
 SIG 35W-82
 0219 m B
 0089 m E

SIGNAL CAB
 SYS. ID. NO. 20585
 35W @ 82nd EAST RAMP

BY	DATE	REVISIONS

SYSTEM ID: 20582, 20584	T.E.
METER ADDRESS:	
MASTER ID:	T.E.

FIBER OPTIC SCHEMATIC

S.A.P. NO. 107-130-043	DRAWN BY: BAM	CKD BY: CDB	DATE: 12/13/12
CERTIFIED BY: <i>Michael P. Gelinsky</i>	LIC. NO. 19863	DATE: 12/13/12	
STATE PROJ. NO. 2782-321 (T.H.35W)		SHEET NO. SS20 OF SS23 SHEETS	

⊗ = FURNISHED SPLICE NO SPLICE OTRD READING REQUIRED AT THIS LOCATION
 ⊕ = FURNISHED SPLICE NO SPLICE OTRD READING REQUIRED AT THIS LOCATION

⊗ ⊕ POWER METER TEST POINT
 ⊗ ⊕ INSERT OPTICAL LINK LOSS IN dB (TEST MULTI-MODE FIBER AT 1310) (TEST SINGLE MODE FIBER AT 1550)

⊗ ⊕ FURNISHED SPLICE
 ⊗ ⊕ INSERT OTRD SPLICE LOSS SHOT FROM THIS DIRECTION
 ⊗ ⊕ INSERT OTRD SPLICE LOSS SHOT FROM THIS DIRECTION

MNDOT INSTALLED PATCHCORDS

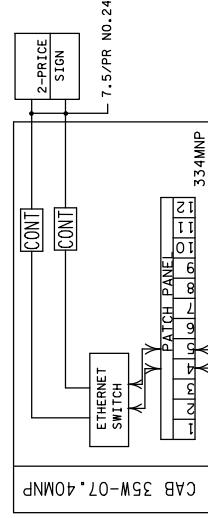

PIGTAIL ID#:
 CAB 35W-07.40
 1538 m B
 1321 m E

PIGTAIL ID#:
 DMS07.55
 0047 m B
 0061 m E

PIGTAIL ID#:
 C613
 1301 m B
 1237 m E

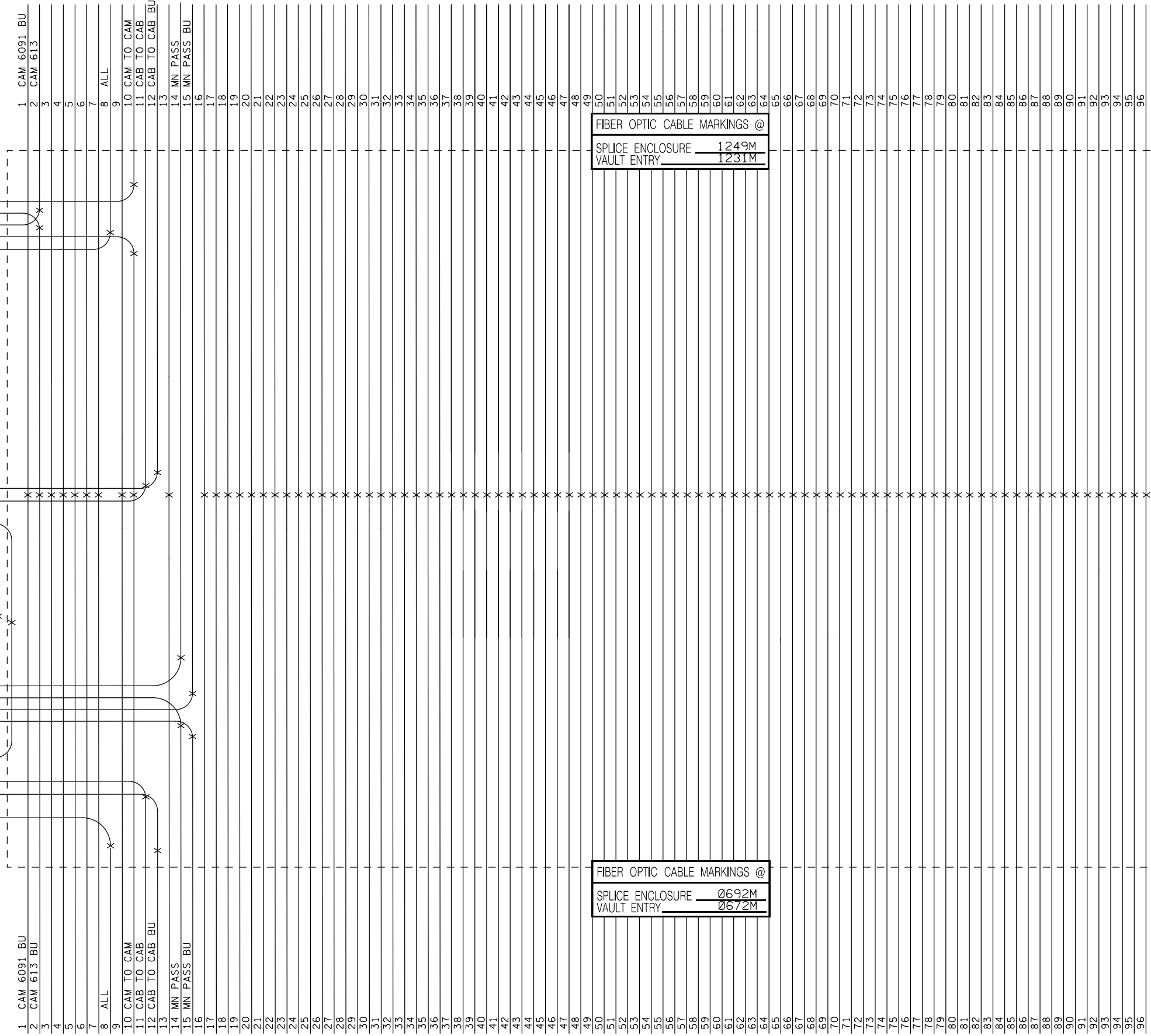

FIBER OPTIC CABLE MARKINGS @
 SPLICE ENCLOSURE 0692M
 VAULT ENTRY 0672M

FIBER OPTIC CABLE MARKINGS @
 SPLICE ENCLOSURE 1249M
 VAULT ENTRY 1231M

BY	DATE	REVISIONS

SYSTEM ID: 20582, 20584	T.E.
METER ADDRESS:	
MASTER ID:	T.E.

FIBER OPTIC SCHEMATIC

S.A.P. NO. 107-130-043	DRAWN BY: BAM	CKD BY: CDB	DATE: 12/13/12
CERTIFIED BY: <i>Michael P. Delaney</i>	LIC. NO. 19863	DATE: 12/13/12	
STATE PROJ. NO. 2782-321 (T.H.35W)		SHEET NO. SS19 OF SS23 SHEETS	

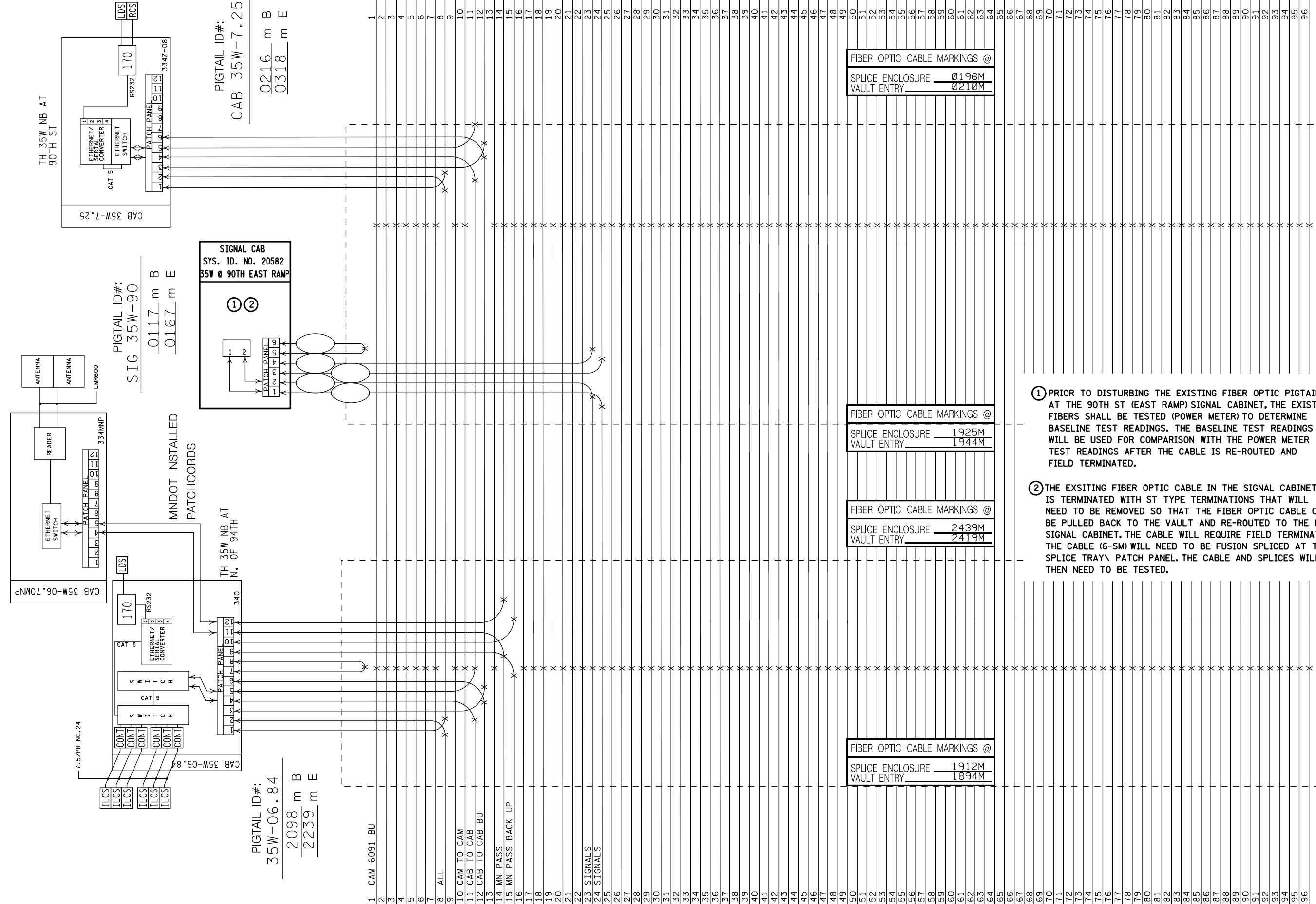

VAULT @ 90TH (EAST) F-35WU.53

VAULT @ 94TH (EAST) F-35WU.50

VAULT @ 94TH (EAST) F-35WU.47

SHEET 2 OF 4

BY	DATE	REVISIONS	SYSTEM ID: 20582, 20584	T.E.	S.A.P. NO. 107-130-043	DRAWN BY: BAM	CKD BY: CDB	DATE: 12/13/12
			METER ADDRESS:		CERTIFIED BY: <i>Michael P. Gelinsky</i>	LIC. NO. 19863		DATE: 12/13/12
			MASTER ID:	T.E.	STATE PROJ. NO. 2782-321 (T.H.35W) SHEET NO. SS18 OF SS23 SHEETS			

FIBER OPTIC SCHEMATIC